

Retractable H Tungsten Spring/Screw Tensioned

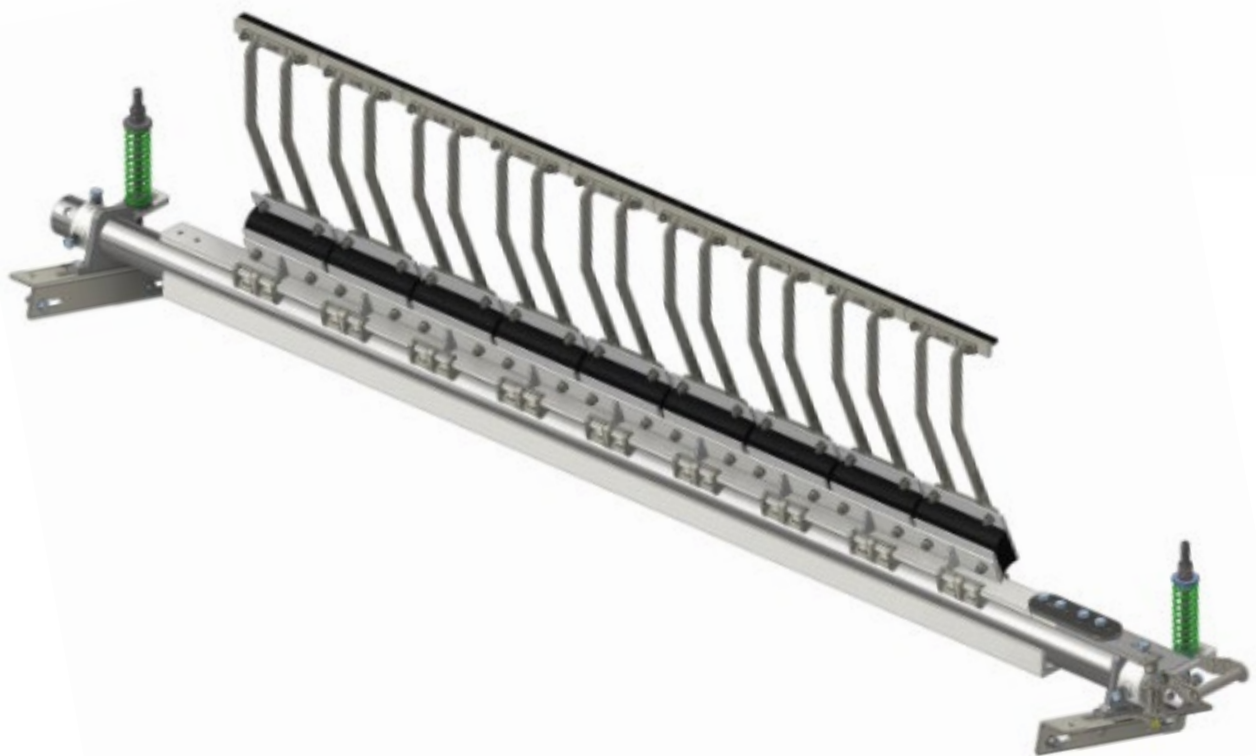

TSGlobal
Conveyor & Polyurethane Specialists

Installation, Operation and Maintenance Manual

Revision History

Rev	Date	Description	Document Owner
01	21/05/2021	Retractable H Tungsten Belt Cleaner	Ray Macarthur
02	07/02/2022	Retractable H Tungsten Belt Cleaner	Alexandra McBeath
03	23/03/2022	Update of Coordinates Chart	William Manrique

Contents

Section 1 – Important Information	4
General Information	4
User Benefits.....	4
Service Option.....	4
Warranty	4
Section 2 – Safety Considerations, Precautions and Correct Storage	6
Operating Conveyors	6
Isolated Conveyors.....	6
Correct Storage	6
Section 3 – Installation Instructions.....	7
Checklist	7
Before you begin:.....	7
Suggested Tools Required for Installation	9
Install Mounting Assemblies	9
Pivots and Tensioners	10
Tip Alignment.....	12
Cleaner Installation	13
Pole Adjustment and Tip Tension	16
Adjustment Process	17
Section 4 – Pre-Operation Checklist and Testing.....	18
Pre-Operation Checklist.....	18
Test Run the Conveyor.....	18
Section 5 – Maintenance	19
Routine Visual Inspection (Recommended every 4 weeks).....	19
Routine Physical Inspection (Recommended every 3 months)	19
Tip and Cushion Service Instructions	19
Section 6 – Troubleshooting	20
Section 7 – Replacement Parts	21

Section 1 – Important Information

General Information

TS Global is pleased that you have selected one of our products for your conveyor system.

This manual will assist in the understanding and operation of the product and allow it to perform at its maximum efficiency.

For safe and efficient operation, it is essential that the information and guidelines presented be properly understood and implemented. This manual will provide safety precautions, storage advice, installation instructions, maintenance procedures, recommended spares and troubleshooting tips.

If, however, you have any questions or problems that are not covered in this manual, please contact the nearest authorised distributor, or visit our website. www.tsglobal.net.au

All persons directly responsible for the installation, operation and maintenance of this product should read this manual thoroughly. Whilst we have attempted to make the installation and service tasks as simple as possible, optimum performance from the product will require correct installation, regular inspections, adjustments, and maintenance to maintain maximum efficiency.

User Benefits

Ensuring the correct installation and regular maintenance tasks are performed, our product will provide the following benefits to your operation:

- Increase conveyor availability and reliability.
- Reduced man-hour labour requirements.
- Lower maintenance costs.
- Increased service life for the cleaner and other conveyor components.
- Reduction in Safety Hazards around conveyor.
- Reduction in Environmental Impact.

Service Option

This product is designed to be easily installed and serviced by your on-site personnel, however, if you would prefer a complete turn-key service, please contact TS Global for a list of your nearest distributors.

Warranty

The warranty provided by TS Global Pty Limited (“TS Global”) is set out in the TS Global Terms and Conditions of Sale at clauses 6.1 to 6.5 inclusive. Those clauses are set out below: -

6.1 Subject to these conditions of sale, TS GLOBAL warrants that the Goods are free of defects both in material and workmanship and are of merchantable quality. The liability of TS GLOBAL pursuant to this warranty or any other warranty implied by operation of any statute including the Competition and Consumer Act 2010 (Cth) (as amended) shall be limited to the cost of replacing defective Goods, the cost of obtaining equivalent Goods, or the cost of repairing the Goods at TS GLOBAL’s discretion provided that in all such cases any costs of dismantling and reassembly shall be borne by the Customer.

6.2 The warranty set out at clause 6.1 is subject to the following:

- a) the warranty applies for a period of 12 months commencing on the date of invoice of the Goods;
- b) the warranty does not apply to consumable components that are subject to normal wear and tear;
- c) the Customer must provide TS GLOBAL with either an invoice number or purchase order number referencing the defective Goods;

- d) the defects to the Goods must have arisen solely from faulty materials or workmanship; and
- e) the damage to the Goods must not arise from:
 - i. incorrect installation of the Goods contrary to the instructions contained within TS Global's Installation and Operation Manuals;
 - ii. improper adjustment, calibration or operation by the Customer;
 - iii. the use of accessories including consumables, hardware, or software which were not manufactured by or approved in writing by TS GLOBAL
 - iv. any contamination or leakages caused or induced by the Customer
 - v. any modifications of the Goods which was not authorised in writing by TS GLOBAL;
 - vi. any misuse of the Goods by the Customer;
 - vii. any use or operation of the Goods outside of the physical, electrical or environmental specifications of the Goods;
 - viii. inadequate or incorrect site preparation;
 - ix. inadequate or improper maintenance of the Goods; or
 - x. incorrect handling of the Goods.

6.3 If the Goods are not manufactured by TS GLOBAL the guarantee of the manufacturer of those Goods is accepted by the Customer and is the only guarantee given to the Customer in respect of the Goods. TS GLOBAL agrees to assign to the Customer on request made by the Customer the benefit of any warranty or entitlement to the Goods that the manufacturer has granted to TS GLOBAL under any contract or by implication or operation of law to the extent that the benefit of any warranty or entitlement is assignable.

6.4 Except as provided in these conditions, all express and implied warranties, guarantees and conditions under statute or general law as to merchantability, description, quality, suitability, or fitness of the Goods for any purpose or as to design, assembly, installation, materials, or workmanship or otherwise are expressly excluded. TS GLOBAL is not liable for physical or financial injury, loss, or damage or for consequential loss or damage of any kind arising out of the supply, layout, assembly, installation, or operation of the Goods or arising out of TS GLOBAL's negligence or in any way.

6.5 Nothing in these conditions shall be read or applied so as to exclude, restrict or modify or have the effect of excluding, restricting or modifying any condition, warranty, guarantee, right or remedy implied by law (including the Competition and Consumer Act 2010) and which by law cannot be excluded, restricted or modified.

This Warranty Statement must be read in conjunction with TS Global's Terms and Conditions of Sale which can be located on our website www.tsglobal.net.au

Section 2 – Safety Considerations, Precautions and Correct Storage

Before installing, operating, inspecting, or maintaining this product, it is important to follow and understand all relevant site and statutory regulations. Please review the following safety information.



All statutory and site regulations must be followed before undertaking the following activities. Failure to follow site safety procedures exposes workers to uncontrolled hazards which can result in serious injury or in extreme cases, fatality.

Personal Protective Equipment (PPE) must be worn to control the foreseeable hazards associated with conveyor belts. Confined space, tensioning devices and heavy components create a worksite that may expose a worker to harm. Mechanical devices such as cranes or chain blocks can reduce exposure to harm.

Once hazards have been identified, the installer should undertake written Job Hazard Analysis according to site requirements. The installer must identify all hazards and apply appropriate controls before proceeding with the installation or servicing of this equipment.

There are installation, maintenance and operational activities involving both isolated and operating conveyors. Each has a safety protocol, and it is your responsibility to be familiar with the sites requirements.

Operating Conveyors

There are two routine tasks that should be performed while the conveyor is running:

- Inspecting the performance and operation of the product.
- Dynamic troubleshooting.

Isolated Conveyors

The following activities are performed on isolated conveyors:

- Installation
- Parts replacement
- Repair
- Cleaning

Correct Storage

Provided goods remain stored within boxes or on pallets wrapped with plastic, TS Global products can be stored outside in all weather conditions. If packaging is damaged or removed, TS Global recommends that the products be stored under cover and out of direct sunlight to minimise deterioration of any componentry.

Section 3 – Installation Instructions

Checklist

- Check that the product size is correct for the conveyor to be installed on.
- Check the product and make sure all the parts have been supplied.
- Review the “Tools Needed” listed on page 8 of the Installation instructions.
- Check the installation location: will the cleaner fit inside chute.

Before you begin:

- Familiarise yourself with the main components of this product (Fig. 1a).
- Determine the install location and check for clearances (Fig. 1b).
- Follow all safety precautions and site hot work procedures (as required).
- Protect all fastener threads and the belt from weld spatter.

Note: TS Global belt cleaners have been designed to be flexible in installation. In the event that conveyor head chute or structure needs to be modified, seek engineering approval from your site contact, prior to undertaking modification.

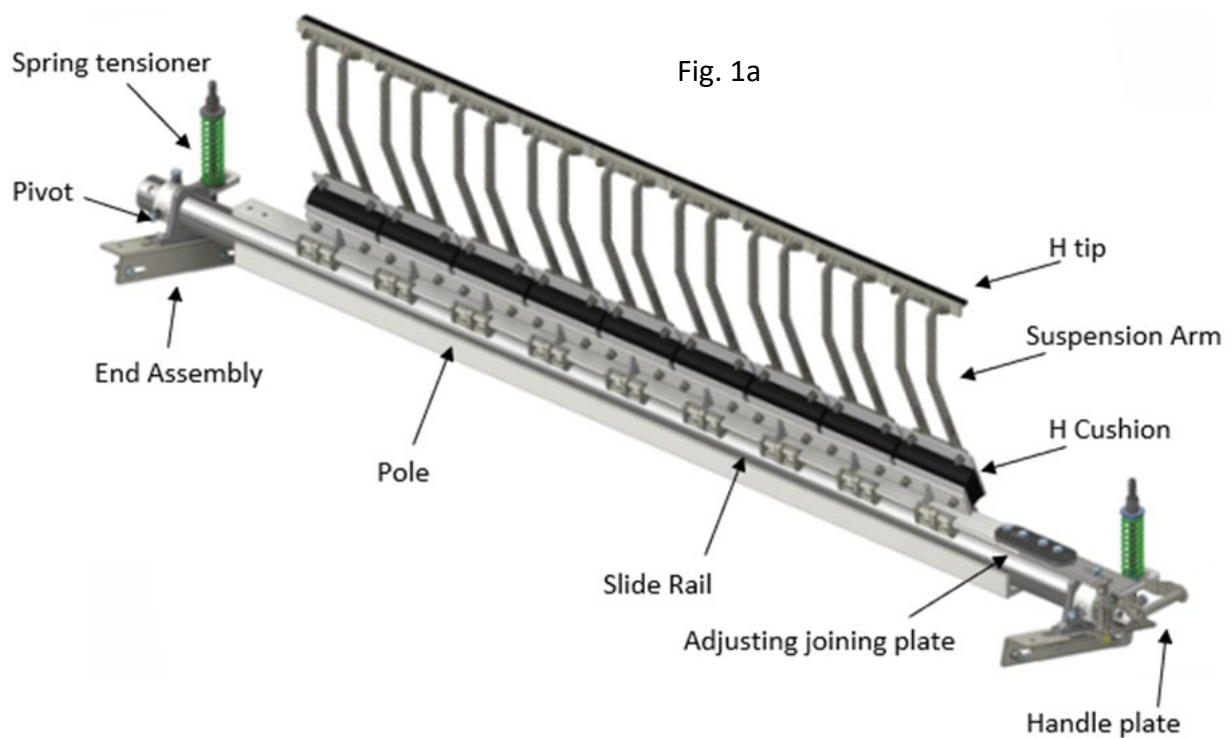

Use table to determine recommended suspension arm size.

Pulley diameter including lagging & belt thickness	Recommended arm size
250mm to 500mm	SS
500mm to 800mm	S
800mm to 1000mm	M
1000mm to 1200mm	L
1200mm to 1700mm	LL

To determine positioning of H tungsten cleaner pole, X and Y coordinates will need to be identified. The following chart below can be used.

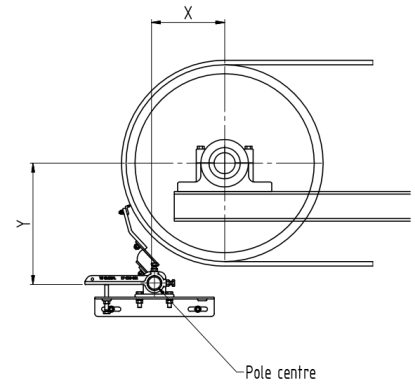

TS Global Reference chart

TS Global H Cleaner Coordinates Chart				
Pole Dia		73 Poles		
Arm size	Pulley Dia	Dim X	Dim Y	Dim C
S	500	146	427	451
	600	194	440	481
	700	242	453	513
	800	291	466	549
M	700	224	504	551
	800	273	517	584
	900	321	529	619
	1000	369	542	656
L	1000	345	566	663
	1100	393	579	700
	1200	441	592	738
	1300	488	709	861
LL	1200	440	696	823
	1300	488	709	861
	1400	536	772	899
	1500	585	735	939
	1600	633	747	980
	1700	681	760	1021

Note: standard pole coordinates will set cleaner tips at recommended 15 degrees below horizontal plane of the head pulley. If standard coordinates cannot be used due to chute configuration use Dim C in above chart for best mounting position or refer to coordinates calculator.

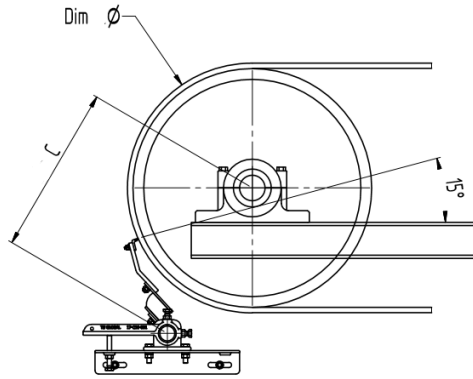

Alternatively, supply TS Global with the Pulley Diameter (including lagging) and the belt thickness and we will advise the recommended set up or alternatives.

Suggested Tools Required for Installation

- Tape measure
- Marking Pen
- Level
- 2 x 150mm G Clamps
- 2 x 13mm spanners
- 2 x 17mm spanners
- 2 x 19mm Spanners
- 2 x 24mm Spanners (HD mounting)
- Cutting Torch and or Welder
- Grinder
- Drill
- Various drill bits up to 13mm

Install Mounting Assemblies

1. Mark a horizontal reference line from the pulley centre.
2. Measure vertically down dimension Y and mark the horizontal pole centre line.
3. Measure out dimension X distance and mark the vertical pole centre line.
4. Where the horizontal and vertical pole centre lines intersect is the correct pole mounting centre.

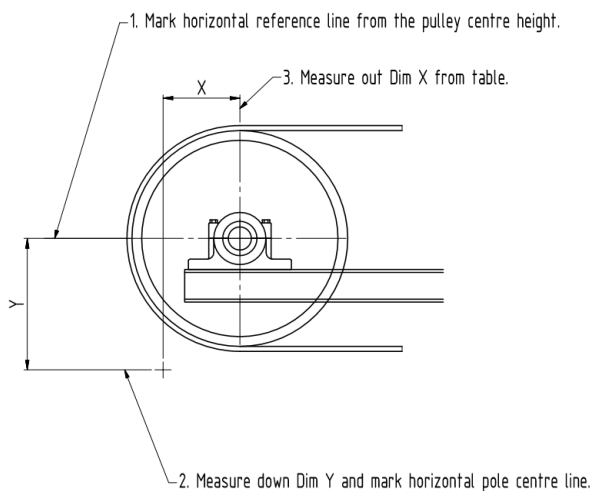

Pivots and Tensioners

1. In most applications, the standard mounting brackets will have adequate room to fit on the structure with no cutting.
2. Locate the pivots in the centre of the mounting brackets and nip up only. This will allow adjustment of the X dimension for fine tuning the tip attack angle.

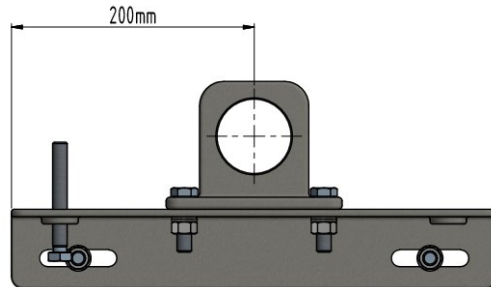

3. Confirm diameter of cleaner pole and utilising below table, mark a second horizontal line at dim A below the existing pole horizontal centre line

Pole dia	Dim A
48mm	50mm
60mm	60mm
73mm	65mm

4. Clamp the mounting bracket into a horizontal position with 150mm clamps as per the sketch below. Recheck mounting position before proceeding.

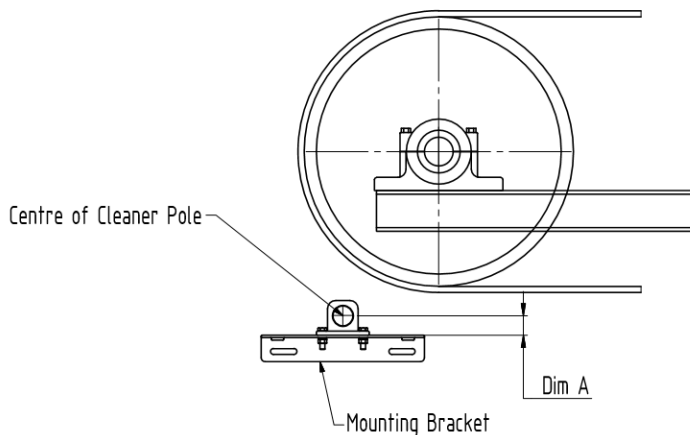

5. Weld or bolt the mounting bracket into position and repeat for the opposite side.
6. Remove the operator's side pivot mount to allow the pole installation.
7. If installing into a chute, access and maintenance cut outs will be required. **-Note:** larger cut-outs will be required if Polyurethane blades are to be used. (See Poly H Cleaner Manual)

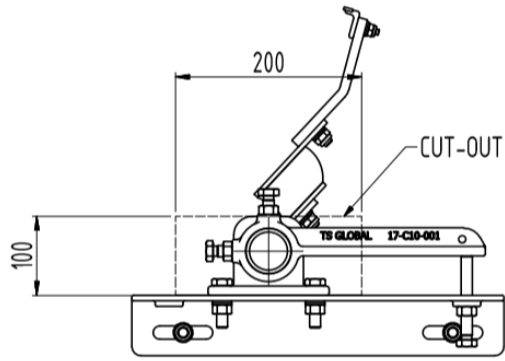

Far side cut out

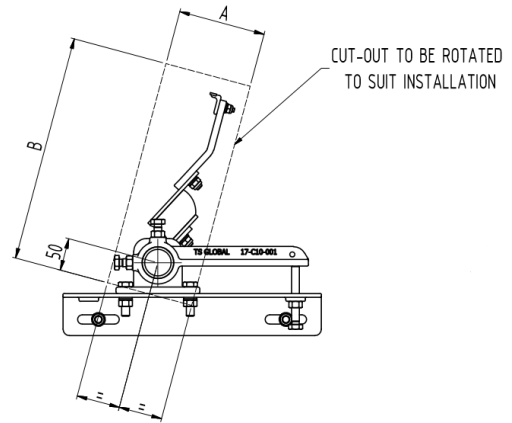

Operators side cut out

Arm Size	Operator side cut out DIM A mm	Operator side cut out DIM B mm
SS	100	320
S	100	370
M	120	450
L	120	480
LL	120	580

Tip Alignment

TS Global belt cleaners are factory set with tips aligned straight.

NOTE: For crowned pulleys or worn belt profiles, all cleaner tips will not make even contact across the width of the belt. To maximise full performance and efficiency, cushion shimming will be required to adjust the tips to the belt profile. If this is not done correctly, the cleaner will not perform at maximum efficiency. All shimming shall be done between the cushion and the pole.

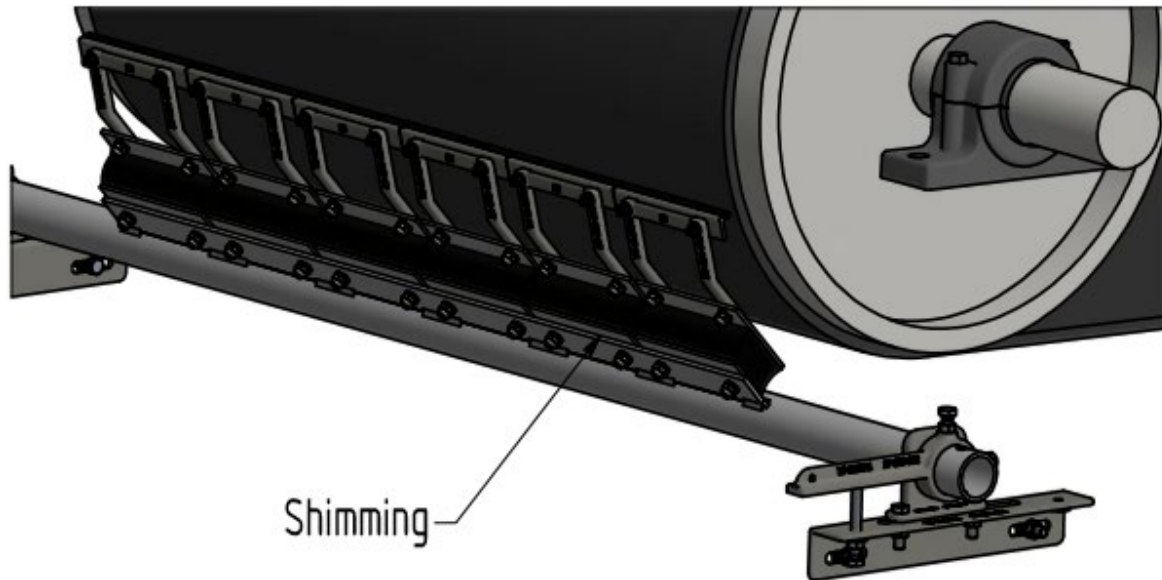

Loosen both retaining nuts on the cushion to be shimmed. Shims can be added to either the top or bottom of the cushion depending on which way the tip is required to be moved i.e.:

- To move the tip forward, loosen nuts on cushion and add shim between the top of the cushion and the pole.
- To push the tip back, loosen nuts on cushion and add shim to the bottom of the cushion.

Once required shims are positioned to obtain full tip contact with the belt profile, tighten cushion nuts, and repeat for next cushion. Ensure there is 0.5 to 1mm clearance between each tip to prevent chipping.

Cleaner Installation

1. Remove the cleaner cartridge from the cleaner pole before installation.
2. Install the cleaner pole onto the mounting brackets. Insert and slide the pole through the chute cut outs and into the far side pivot mount. When the pole is in place on the conveyor and central to the head pulley, install the near side pivot mount and nip the pivot bolts into position. The cleaner will need to be squared to the belt once assembly is completed.
3. Rotate the cleaner pole so that the claws for the cartridge are in line with the large cut-out in the side of the chute to allow the cartridge to be installed.

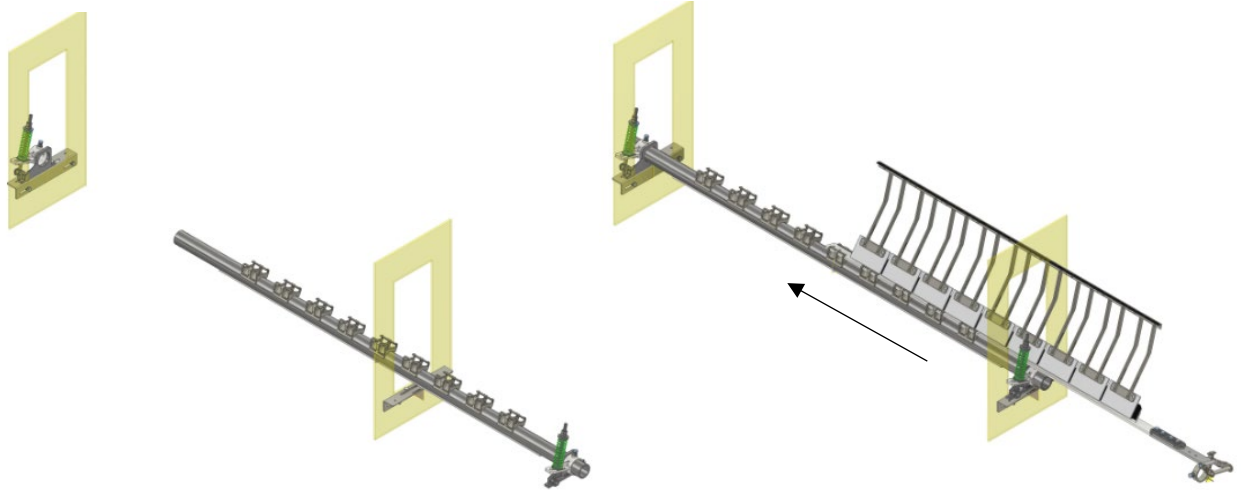

4. Fit both adjuster arms to cleaner pole, and lock lightly onto the pole to prevent pole movement as the cartridge is installed. Do not fully tighten at this stage.

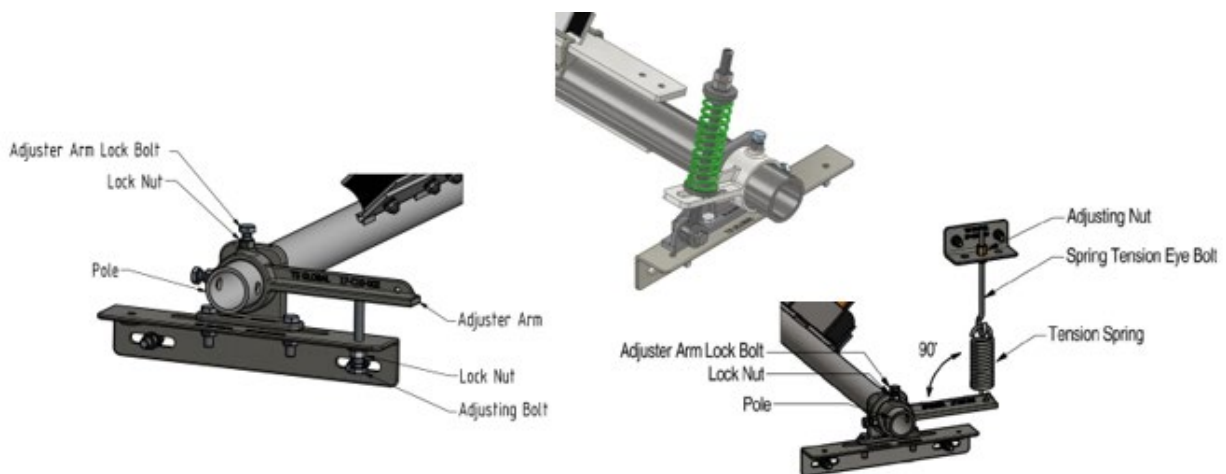

Fig.2a

Shown above are the screw adjuster, compression spring adjuster and tension spring adjuster assemblies.

5. Slide the cartridge (fitted with the tips arms and cushions) into position and central to the conveyor head pulley. There are several cartridge options-
 - a. Single piece cartridge with single sided operation.
 - b. Multi section cartridge with single sided operation.
 - c. Two section cartridges with double sided operation.
6. Rotate the cleaner upward until the tips touch the belt (refer fig 3b).
7. Centre the tips across the belt and tighten both adjuster arms to retain the cleaner in the centre position (refer figure 3a).

- Ensure the adjuster arms horizontal and resting on the adjusting bolt as shown in Fig 2a. If spring tension adjuster arms are used follow the procedure in the tensioning section to adjust to correct position and tension.

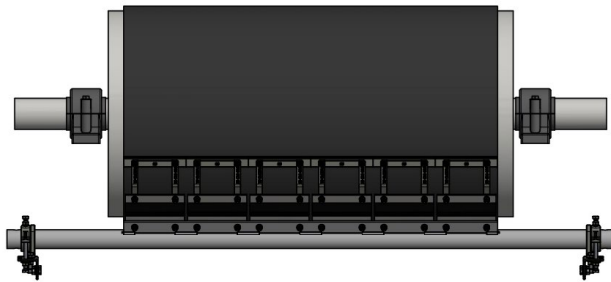

Fig. 3a

Cleaner centred to the pulley.

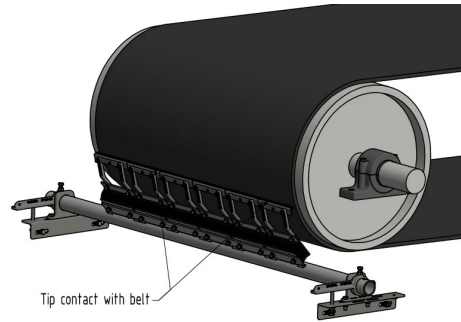
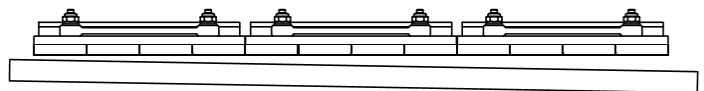
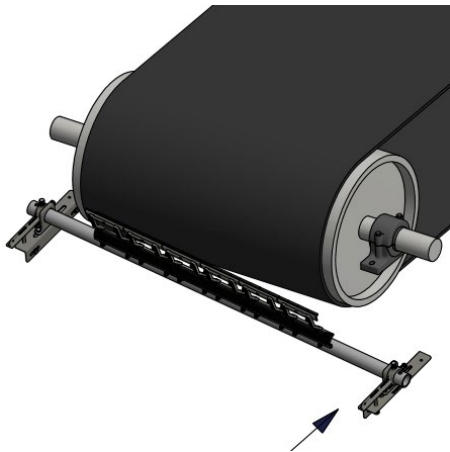

Fig. 3b

Cleaner aligned with belt.

- Adjust the pivot mount by pushing under the pulley until the cleaner tips are parallel to the belt surface. This is to ensure the cleaner is aligned correctly with the belt.



INCORRECT - Tips are not aligned with belt profile.



CORRECT - Tips are aligned with belt profile.

For worn belt profiles, cleaner tips will not make even contact across the width of the belt. To maximise full performance and efficiency tips will need to be aligned to belt profile. To assist with this a straight edge can be placed across the surface of the belt to help understand wear pattern in the belt. Working left to right rise or lower tips accordingly.

- Check cleaner suspension arms to align as detailed on the tip angle gauge. Slide the pivots along the mounting brackets as required to position the cleaner correctly. Align the two edges of the gauge marked "Belt Line" with the belt on the pulley and the other edge marked "Align this edge with top of H tip" to the tip as shown above.

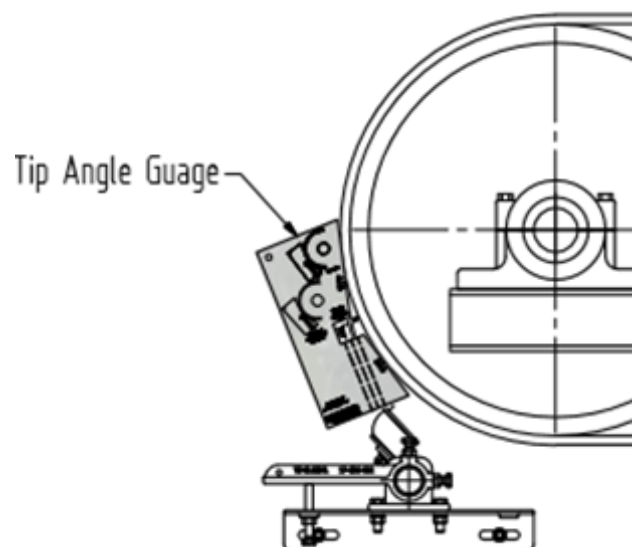

- Lock pivot mount in place
- Utilising adjusting bolt or nut, adjust cleaner up until tips contact the belt.
- Adjust the cleaner tips back off the belt to line up to the cut out on the side of the chute.

14. Slide the carriage back out where you can work on it, then bolt the joining plate and handle plate in place onto the end of the cartridge on the side that the cleaner is to be withdrawn from for servicing.
15. Slide the cartridge back in place and check it is central to the belt and structure where the cleaner will operate.
16. Slide the pin locking ring onto the end of the pole where it can operate safely and tighten it to the pole.
17. Measure the distance the handle plate needs to be shortened by to line the locking pin holes up.
18. Cut the handle plate to the required length then bolt it in place using the adjusting plate to join it to the cleaner cartridge.

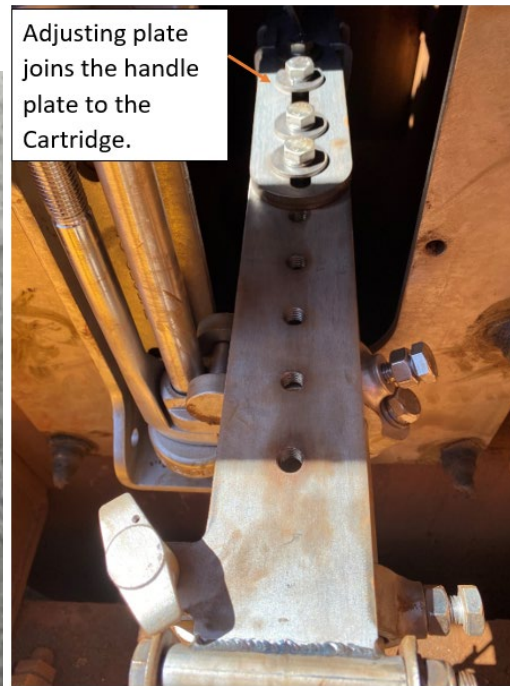

19. Bolt the handle plate back onto the cartridge and place the locking pin in position to lock the cleaner in position.
20. Adjust the cleaner tips back onto the belt and apply tension to the cleaner by following the tension procedure.

Pole Adjustment and Tip Tension

There are 4 standard tension systems available for the H Tungsten belt cleaner.

- Screw adjuster
- Tension type spring adjuster
- Compression type spring adjuster
- Hydraulic tension system

Screw Tension uses a set screw in the mounting bracket to provide torsion through an adjuster arm to the pole to place stored tip tension through the rubber cushion. Any adjustment for wear in the tip or belt is a manual process. Tip tension is difficult to confirm during belt operation. This tension system is designed primarily for Tungsten tip cleaners only as polyurethane cleaners require more regular adjustment for wear.

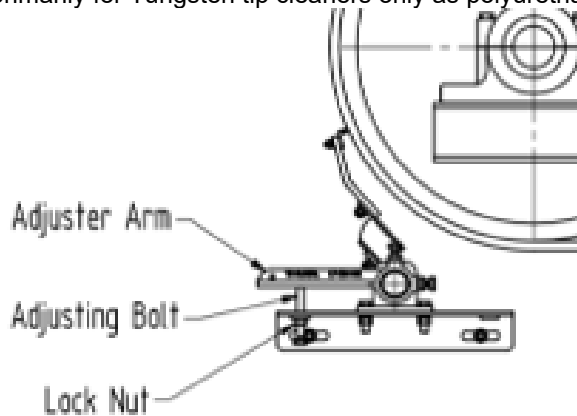

Screw Adjuster

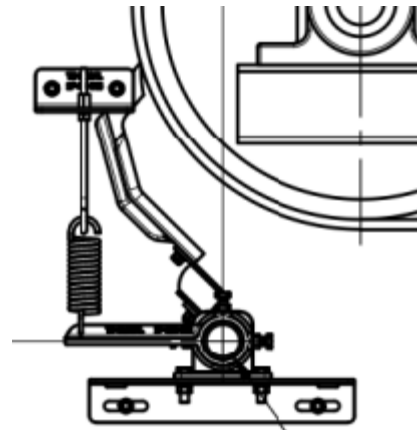

Tension Spring

The Tension spring uses a threaded hook bolt to adjust tension through the adjuster arm with an angle bracket mounted somewhere on the head chute to provide the torsion. This tension system can be used for both Tungsten and Polyurethane H type cleaner blades.

The compression spring system uses a threaded rod incorporated into the pivot bearing providing torsion to the cleaner pole. This system is more self-contained and does not rely on a mounting point for the spring outside of the mounting bracket. Tip tension can be monitored externally by checking the spring compression length against the spring tension chart. This tension system can be used for both Tungsten and Polyurethane H type cleaner blades.

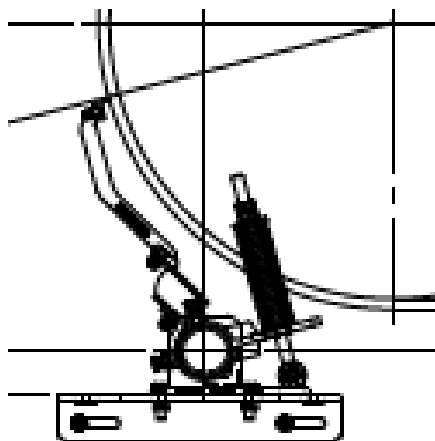

Compression Spring.

The Hydraulic tensioner uses a hydraulic cylinder to provide tension to the cleaner. It has the advantage of a constant regulated pressure that compensates for tip and belt wear and tension can be confirmed from a pressure gauge. The Hydraulic tensioner is not covered in this manual. (See Hydraulic Tensioned H Cleaner Manual.)

Adjustment Process

21. To check the tip attack angle, a tip angle gauge is provided with the cleaner and can be used to verify the tip attack angle.
22. Align the two edges of the gauge marked "Belt Line" with the belt and the other edge marked "Align this edge with top of H tip" to the tip as shown below.
23. Cleaner suspension arms to align as detailed on gauge

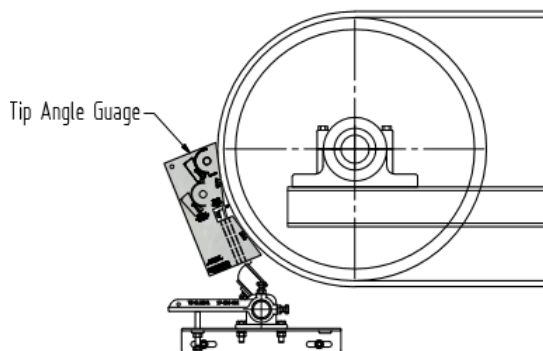

24. Now that the tips are adjusted and aligned to the belt profile, check all mounting, pivot and adjuster arms fasteners are all tightened. The tips should be following the belt profile and have 0.5 to 1mm clearance between the tips to prevent chipping of the tungsten.
25. Adjust the tension on the adjuster arms by using the adjusting bolt. If a spring tension system is used the tip tension can be checked the same way.
26. Using a spring scale, pull back on suspension arm until tip clears belt. Scale to read 7 to 8kgs per tip (9 to 11kg on HD Tungsten tips and Polyurethane blades). As a guide, 3 full turns on adjuster bolt minimum when using a M12 adjuster. 2 full turns on adjuster bolt minimum when using a M16 adjuster.

With spring tensioner, spring tension depends on the belt width and number of tips.

For **tension springs** the spring coil gap should be between 1 to 3 mm.

For **Compression springs** use the spring Tension chart as a guide but always check tip tension with a spring scale to confirm correct tip tension.

Compression spring lengths for H type cleaners Using Standard Duty Tips																	
Suspension Arm Size	Tip Force (kg)	Tip Type	Belt Size														
			600	800	1050	1200	1400	1600	1800	2000	2200	2400	2600	2800	3000	3200	3400
SS	7	Standard	133.3	127.7	122.1	116.6	111.0	131.6	129.3	127.0	124.7	122.4	120.1	117.8	115.5	113.2	110.9
S	7	Standard	129.6	122.7	115.9	133.1	130.3	127.5	124.7	121.8	119.0	116.2	113.4	110.6	107.8	104.9	102.1
M	7	Standard	126.3	118.4	110.5	130.4	127.1	123.9	120.6	117.3	114.1	110.8	107.5	104.2	101.0	97.7	113.8
L	7	Standard	124.5	116.0	132.4	128.9	125.4	121.9	118.3	114.8	111.3	107.8	104.3	100.8	97.2	113.3	111.0
LL	7	Standard	118.3	132.5	128.1	123.8	119.4	115.0	110.7	106.3	101.9	97.5	112.9	110.1	107.2	104.4	101.5

Compression spring lengths for H type cleaners Using Heavy Duty Tungsten Tips or Polyurethane Mono-Arms																	
Suspension Arm Size	Tip Force (kg)	Tip Type	Belt Size														
			600	800	1050	1200	1400	1600	1800	2000	2200	2400	2600	2800	3000	3200	3400
SS	9	H/D & Poly	128.8	121.7	114.6	132.4	129.5	126.6	123.7	120.7	117.8	114.9	112.0	109.0	106.1	103.2	100.3
S	9	H/D & Poly	124.2	115.6	132.2	128.7	125.1	121.6	118.0	114.4	110.9	107.3	103.8	100.2	96.7	112.9	110.6
M	9	H/D & Poly	120.1	133.5	129.4	125.2	121.1	117.0	112.9	108.7	104.6	100.5	96.4	112.3	109.6	107.0	104.3
L	9	H/D & Poly	117.8	132.2	127.8	123.3	118.9	114.5	110.0	105.6	101.1	96.7	112.3	109.4	106.5	103.6	100.7
LL	9	H/D & Poly	133.4	127.9	122.4	116.8	111.3	105.8	100.3	114.0	110.3	106.7	103.1	99.5	95.9	92.3	88.7

TUFF EP Spring	85-C10-009
TUFF H Standar	17-C13-009
TUFF H Heavy D	17-C13-010

27. With tension set, tighten the lock nut for the screw adjuster.
28. Cleaner is now installed.

Section 4 – Pre-Operation Checklist and Testing

Pre-Operation Checklist

- Recheck that all fasteners are secured.
- Check tips are in full contact on the belt.
- Check coordinates of cleaner pole.
- Be sure that all installation materials and tools have been removed from the belt and the conveyor area.

Test Run the Conveyor

- Remove isolation in line with site procedures.
- Run the conveyor for at least 15 minutes and inspect the product performance.
- Check all components for proper positioning and tensioning.
- Check cleaner for excessive vibration or material passing tips.
- Adjust as necessary. In some case this may require isolation of the conveyor.

NOTE: Observing the product when it is running and performing properly will help to detect problems. If vibration occurs or material is passing tips refer to section 6 - troubleshooting

Section 5 – Maintenance

TS Global products are designed to operate with minimum maintenance, however, to maintain superior performance some service is required. When the product is installed, a regular inspection and maintenance program should be established. This program will ensure that the product operates at optimal efficiency and problems can be identified and rectified before reduction in performance occurs.

Routine Visual Inspection (Recommended every 4 weeks)

A visual inspection of the cleaner and belt can determine:

- If cleaner tips are in full contact with belt
- If the belt looks clean and cleaner has correct tension
- If the tips or cushions are worn out and need to be replaced
- If there is damage to other cleaner components and locating pins are in place.
- If material is built up on the cleaner
- If there is cover damage to the belt
- If there is vibration of the cleaner

If any of the above conditions exist, a determination should be made on when the conveyor can be stopped for maintenance.

Routine Physical Inspection (Recommended every 3 months)

When the conveyor is not in operation and isolated, undertake a physical inspection of the product to perform the following tasks:

- Clean material build-up off cleaner
- Closely inspect the tips and cushions for wear and/or any damage Replace if needed.
- Ensure full contact of tips across belt.
- Inspect all fasteners for tightness and wear. Tighten or replace as needed.
- Replace any worn or damaged components.
- Ensure cleaner has correct tension.
- When maintenance tasks are completed, test run the conveyor to ensure the cleaner is performing correctly.

Tip and Cushion Service Instructions

1. Prior to commencing tip or cushion replacement, isolate conveyor as per site regulations.
2. Release all tension on the cleaner tips.
3. Loosen adjuster arms and allow the cleaner tips to lay backwards.
4. Remove cleaner from chute.
5. Place cleaner in safe area to allow tip and cushion service or take to workshop for overhaul.
6. Remove all tips, cushions and arms and inspect for damage.
7. Check pole for straightness and wear.
8. Check all components for wear and replace as required.

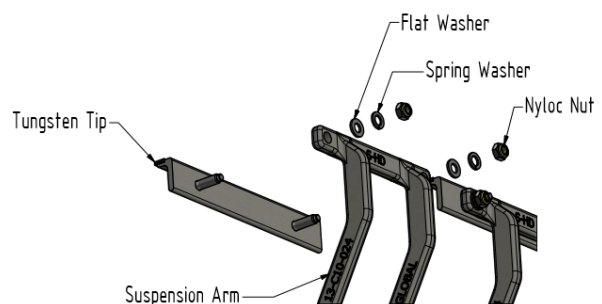

When replacing tips and cushions, ensure both flat and spring washers are utilised with the Nyloc nuts to prevent any possibility of tips coming loose.

9. Replace tips, cushions and arms and align tips as detailed in Section 3, 'Tip Alignment.'
10. Reinstall and adjust cleaner as detailed in Section 3 'Cleaner Installation' and 'Pole Position and Tensioning.'

Section 6 – Troubleshooting

Problem	Possible cause	Possible solution
Vibration	Cleaner pivots or mounting bolts loose	Ensure all locking nuts are tight
	Cleaner not set up correctly	Ensure cleaner set up properly (check tip attack angle with gauge and or coordinates) Cleaner may need to be adjusted under pulley on Y coordinate
	Belt deformed on pulley	Clean or replace pulley lagging
	Cleaner over tensioned	Ensure cleaner is correctly tensioned
	Cleaner under tensioned	Ensure cleaner is correctly tensioned
Material build-up on cleaner	Cleaner not set up correctly	Ensure cleaner set up properly (check tip attack angle with gauge and or coordinates)
	Excessive sticky material	Frequently clean unit of build-up.
Damaged belt cover	Cleaner over-tensioned	Check cleaner is correctly tensioned
	Cleaner tip damaged	Check tips for wear, damage and chips, replace where necessary
	Attack angle incorrect	Ensure cleaner set up properly (check tip attack angle with gauge and or coordinates)
	Material built up in chute	Frequently clean unit of build up
Cleaner not conforming to belt	Cleaner not set up properly	Ensure cleaner set up properly (check tip attack angle with gauge and or coordinates)
	Cleaner cannot conform to belt profile	Align cushions and tips detailed in Section 3
	Wear profile in belt cover	Align cushions and tips as detailed in Section 3
Material passing cleaner	Cleaner not set up properly	Ensure cleaner set up properly (check tip attack angle with gauge and or coordinates)
	Cleaner tension too low	Ensure cleaner is correctly tensioned
	Cleaner tips worn or damaged	Check tips for wear, damage and chips, replace where necessary
	Belt deformed on pulley	Replace pulley lagging
	Build up on lagging	Clean down lagging or replace lagging
	Wear profile in belt cover	Align cushions and tips as detailed in section 3
Missing material in belt centre only	Lagging damaged	Align cushions and tips as detailed in section 3
	Cleaner tips worn/damaged	Check tips for wear, damage and chips, replace where necessary
Missing material on outer edges only	Crowned pulley	Set up cushions as detailed in section 3
	Cleaner tips worn/damaged	Check tips for wear, damage and chips, replace where necessary

Section 7 – Replacement Parts

NOTE- All retractable H Cleaners use 73mm diameter poles.

73mm Screw Tension Complete Side Assembly – (Part 13-A10-006) Below.

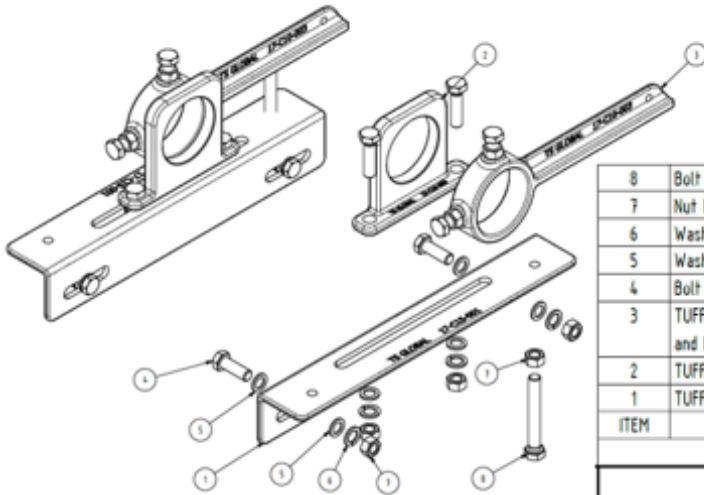

ITEM	DESCRIPTION	PART NUMBER	QTY	MASS
8	Bolt Hex Set Screw M12 x 90 Gr 304 SS DIN933	10-12-046	2	0.099 kg
7	Nut M12 Gr304 SS DIN934	10-32-050	6	0.016 kg
6	Washer Spring M12 Gr 304 SS DIN127B	10-84-050	4	0.004 kg
5	Washer Plain M12 Gr 304 SS DIN125A	10-83-055	8	0.003 kg
4	Bolt Hex Set Screw M12 x 35 Gr 304 SS DIN933	10-12-040	4	0.048 kg
3	TUFF H and U Adjuster Arm for 73 Dia Poles with Nuts and Bolts	17-C10-003	2	1.409 kg
2	TUFF H Pivot Mount for 73 Dia Poles	13-C10-030	2	1.217 kg
1	TUFF H P and R Mounting Bracket	17-C15-001	2	2.183 kg
PARTS LIST				
TUFF H Belt Cleaners				
TUFF H Complete Side Assembly for 73 Dia Poles				

73mm Tension Spring Complete Side Assembly – (Part 13-A10-003) Below.

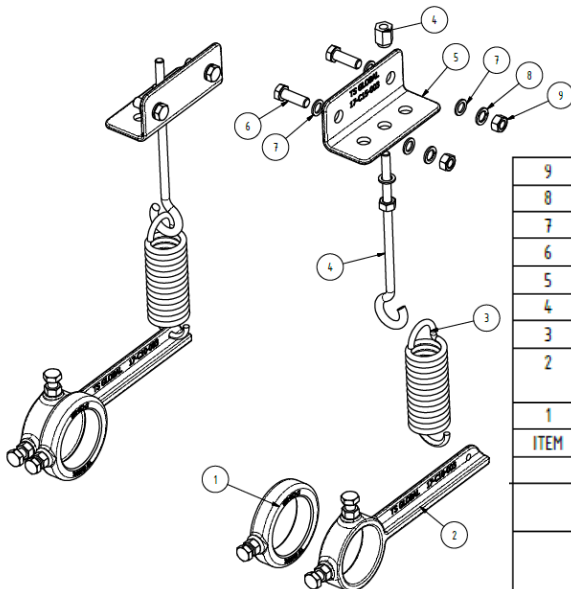

ITEM	DESCRIPTION	PART NUMBER	QTY	MASS
9	Nut M12 Gr304 SS DIN934	10-32-050	4	0.016 kg
8	Washer Spring M12 Gr 304 SS DIN127B	10-84-050	4	0.004 kg
7	Washer Plain M12 Gr 304 SS DIN125A	10-83-055	8	0.003 kg
6	Bolt Hex Set Screw M12 x 35 Gr 304 SS DIN933	10-12-040	4	0.048 kg
5	TUFF H and U Spring Tension Bracket	17-C15-003	2	0.807 kg
4	TUFF H and U Spring Tension Eye Bolt	17-C13-001	2	0.254 kg
3	TUFF H and U HD Tension Spring	17-C13-002	2	0.640 kg
2	TUFF H and U Adjuster Arm for 73 Dia Poles with Nuts and Bolts	17-C10-003	2	1.409 kg
1	Pole Retaining Collar for 73 Dia Poles	17-C16-003	2	0.920 kg
PARTS LIST				
TUFF H Belt Cleaners				
TUFF H Spring Tension Assembly for 73 Dia Poles				

73mm Compression Spring Complete Side Assembly – (13-A10-009) Below

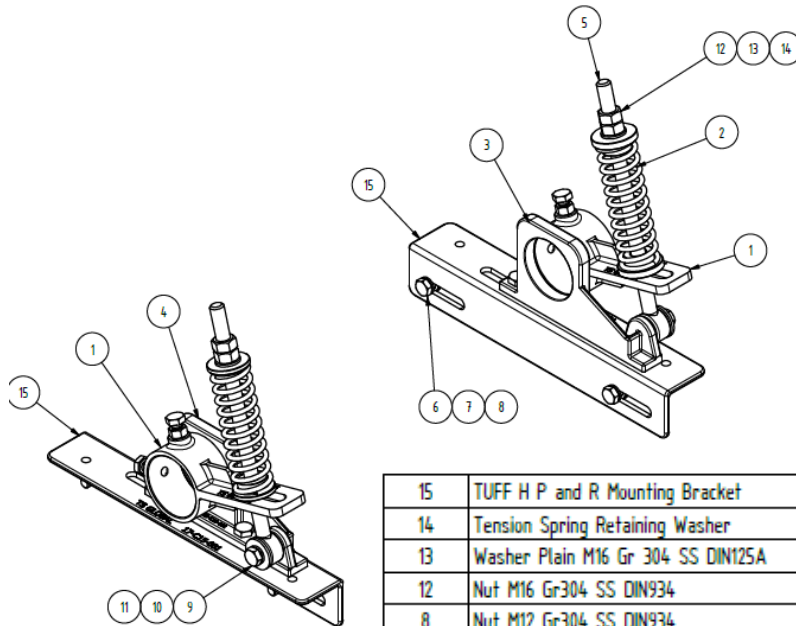

PIVOT MOUNT	48 mm	60 mm	73 mm
PART NUMBER LH	13-C10-087	13-C10-089	13-C10-091
PART NUMBER RH	13-C10-086	13-C10-088	13-C10-090

SPRING	PART NUMBER	COLOUR
TUFF EP SPRING	85-C10-009	GREEN
TUFF H STANDARD DUTY	17-C13-009	RED
TUFF H HEAVY DUTY	17-C13-010	BLUE

POLE DIA	PART NUMBER
48 mm	
60 mm	85-C10-005
73 mm	13-C10-085

15	TUFF H P and R Mounting Bracket	17-C15-001	2	2.2 kg
14	Tension Spring Retaining Washer	86-C10-007	4	0.0 kg
13	Washer Plain M16 Gr 304 SS DIN125A	10-83-060	2	0.0 kg
12	Nut M16 Gr304 SS DIN934	10-32-070	4	0.0 kg
8	Nut M12 Gr304 SS DIN934	10-32-050	4	0.0 kg
11	Washer Spring M12 Gr 304 SS DIN127B	10-84-050	6	0.0 kg
10	Washer Plain M12 x 37 x 3 Mudguard	10-83-050	2	0.0 kg
7	Washer Plain M12 Gr 304 SS DIN125A	10-83-055	8	0.0 kg
6	Bolt Hex Set Screw M12 x 35 Gr 304 SS DIN933	10-12-040	4	0.0 kg
9	Bolt Hex Set Screw M12 x 20 Gr 304 SS DIN933	10-12-030	2	0.0 kg
5	Spring Tension Adjustment Rod	13-C10-083	2	0.6 kg
4	TUFF H Pivot Mount LH	See Table 3	1	1.7 kg
3	TUFF H Pivot Mount RH	See Table 3	1	1.7 kg
2	Tension Spring	See Table 2	2	0.3 kg
1	Adjuster Arm	See Table 1	2	1.2 kg
ITEM	DESCRIPTION	PART NUMBER	QTY	MASS

PARTS LIST

TUFF H Spring Tension Side Assembly

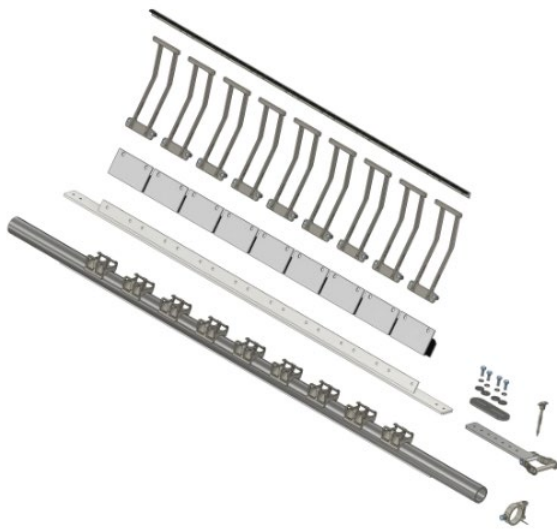

Single sided Retractable H type with single rail

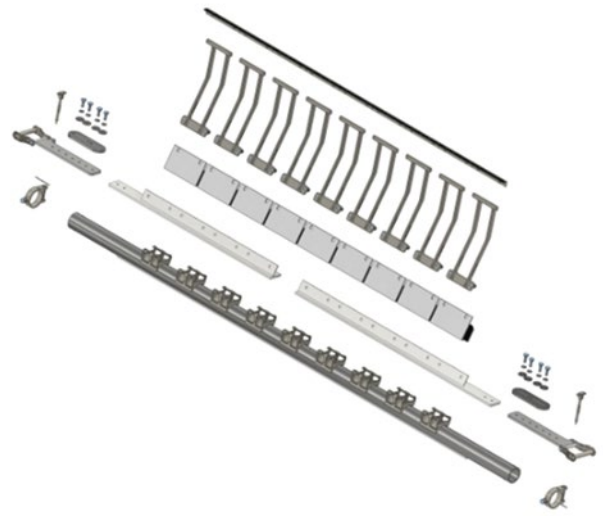

Double sided Retractable H type with split rail.

Below- Single sided Retractable H type with split puzzle joined rail.

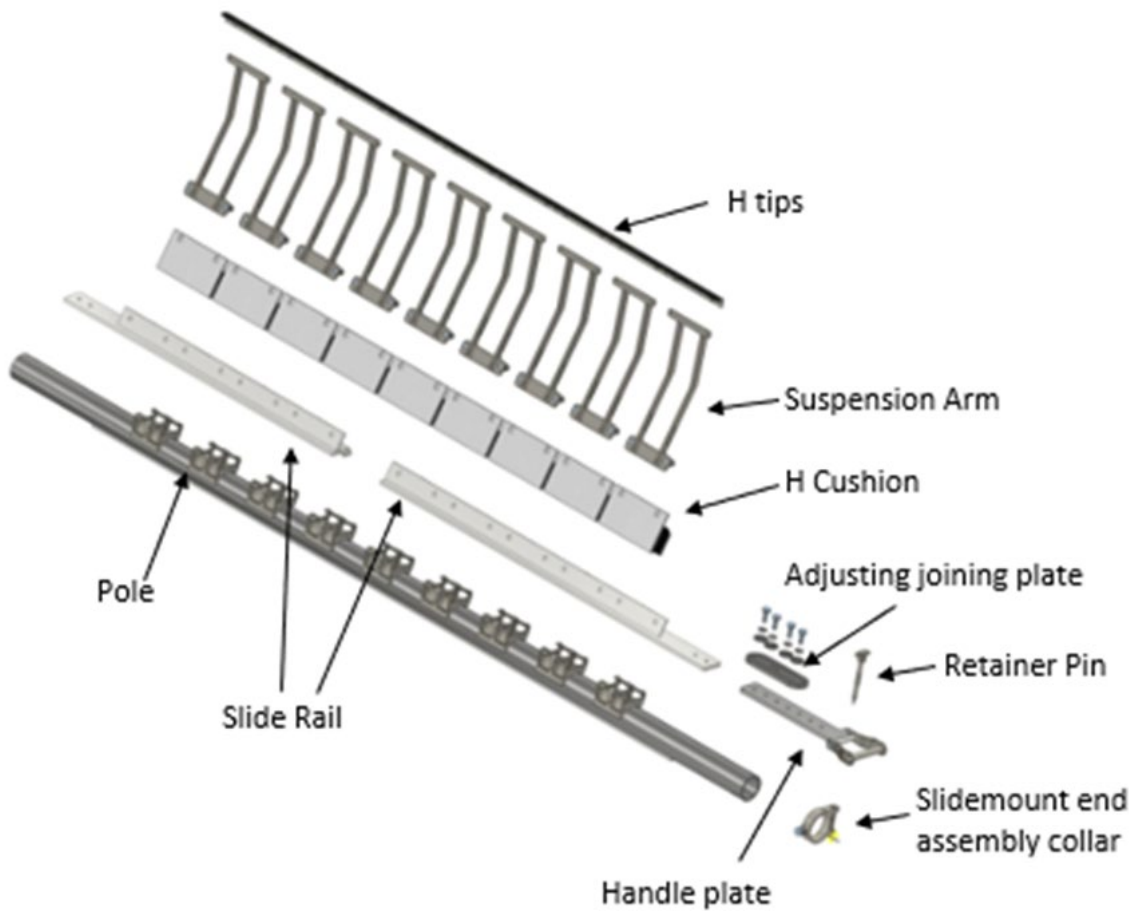

See next Page- for parts list.

Table 4– Suspension Arms			
Description	Standard Duty	Heavy Duty	Extreme Duty
Tuff H Suspension Arm SS	13-C10-018	13-C10-023	N/A
Tuff H Suspension Arm S	13-C10-019	13-C10-024	N/A
Tuff H Suspension Arm M	13-C10-020	13-C10-025	N/A
Tuff H Suspension Arm L	13-C10-021	13-C10-026	N/A
Tuff H Suspension Arm LL	13-C10-022	13-C10-027	13-C10-077

Table 5 – Cushions		
Description	70 shore A Hardness	Extreme Duty
Tuff H Cushion	13-C10-001	13-C10-002

Table 6 – Tips		
Description	Standard Duty	Heavy Duty
Tuff H Tip Tungsten	13-C10-005	13-C10-006
Tuff H Tip T Tungsten	13-C10-007	N/A

Table 7- Poles	
Description	Part Number
Single Rail H Retractable Pole	Contact TS Global
Split Rail H Retractable pole	Contact TS Global

Table 8 – Slide Rails components	
Description	Part Number
Standard single piece H Rail	Contact TS Global
Double-sided Split Rail for H cleaner	Contact TS Global
Single sided puzzle joined multi segment rail for H cleaner	Contact TS Global
Retractable Handle Plate Assembly	17-A11-002
Adjusting Joining Plate	17-C17-005
Bolt Hex Set Screw M12 x 20 Gr 304 DIN933	10-12-030
Washer Plain M12 37 3 Mudguard	10-83-050
Washer Spring M12 Gr 304 DIN127B	10-84-050
Cartridge Retainer Pin	25-C10-002
R clip for Retainer Pin	10-49-001
Slidemount end assembly collar for 73mm diameter poles	17-C17-013



TSGlobal

Conveyor & Polyurethane Specialists

DISTRIBUTED BY

PHONE 1300 418 298 • **EMAIL** sales@tsglobal.net.au • **WEB** www.tsglobal.net.au

WELSHPOOL WA • TOMAGO NSW • EMERALD QLD

ABN 30 603 644 748

