

XHD

Primary Belt Cleaner

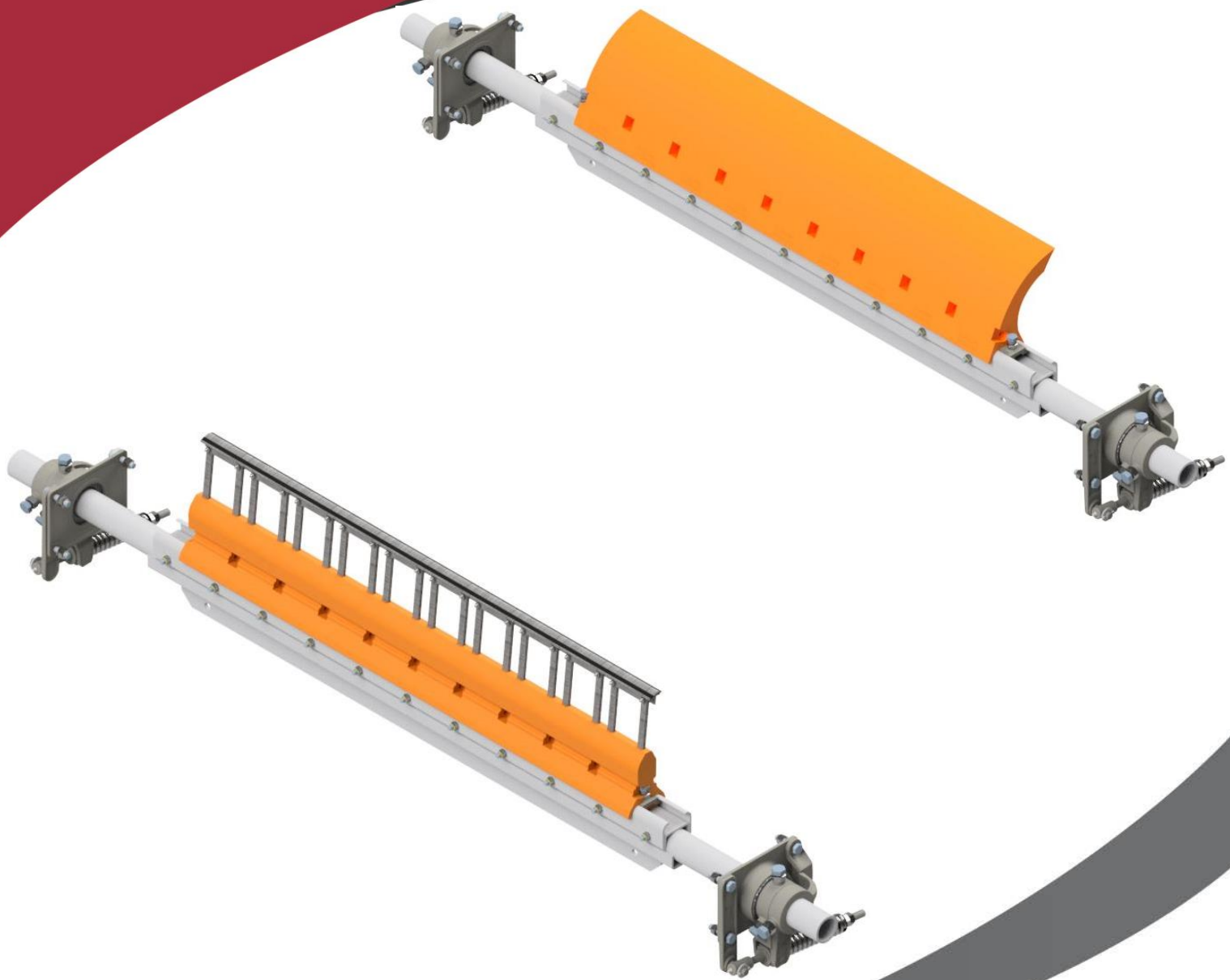

TSGlobal
Conveyor & Polyurethane Specialists

Installation, Operation and Maintenance Manual

Revision History

Rev	Date	Description	Document Owner
01	18/03/2021	XHD P&T Belt Cleaner USA	Ray Macarthur
02	02/02/2022	XHD Manual	Alexandra McBeath

Contents

Section 1 – Important Information	4
General Information	4
User Benefits.....	4
Service Option.....	4
Warranty	4
Section 2 – Safety Considerations, Precautions and Correct Storage	6
Operating Conveyors	6
Isolated Conveyors.....	6
Correct Storage	6
Section 3 – Installation Instructions.....	7
Checklist	7
Blade Profiles	7
Suggested Tools Required for Installation	8
Mounting Plates.....	9
Cleaner Installation	10
For Spring Tensioned Cleaner	11
Spring blade tensioning	11
For Air Tensioned Cleaner.....	12
Air blade tension	12
Section 4 – Pre-Operation Checklist and Testing.....	13
Pre-Operation Checklist.....	13
Test Run the Conveyor.....	13
Section 5 – Maintenance	14
Routine Visual Inspection (Recommended every 4 weeks).....	14
Routine Physical Inspection (Recommended every 3 months)	14
Blade Service Instructions.....	14
Section 6 – Troubleshooting	16
Section 7 – Replacement Parts	17

Section 1 – Important Information

General Information

TS Global is pleased that you have selected one of our products for your conveyor system.

This manual will assist in the understanding and operation of the product allowing it to perform at its maximum efficiency.

For safe and efficient operation, it is essential that the information and guidelines presented in this manual are understood and implemented. This manual will provide safety precautions, storage advice, installation instructions, maintenance procedures, recommended spares and troubleshooting tips.

If, however, you have any questions or problems that are not covered in this manual, please contact the nearest authorised distributor or visit our website, www.tsglobal.net.au

All persons directly responsible for the installation, operation and maintenance of this product should read this manual thoroughly. Whilst we have attempted to make the installation and service tasks as simple as possible the product will require correct installation, regular inspections, adjustments and maintenance to maintain maximum efficiency.

User Benefits

Provided the correct installation and regular maintenance tasks are performed, our product will provide the following benefits to your operation:

- Increased conveyor availability and reliability
- Reduced man-hour labour requirements
- Lower maintenance costs
- Increased service life
- Reduction in Safety Hazards around conveyor
- Reduction in Environmental Impact

Service Option

This product is designed to be easily installed and serviced by your on-site personnel, however, if you would prefer a complete turn-key service, please contact TS Global for a list of your nearest distributors/ service providers.

Warranty

The warranty provided by TS Global Pty Limited (“TS Global”) is set out in the TS Global Terms and Conditions of Sale at clauses 6.1 to 6.5 inclusive. Those clauses are set out below: -

6.1 Subject to these conditions of sale, TS GLOBAL warrants that the Goods are free of defects both in material and workmanship and are of merchantable quality. The liability of TS GLOBAL pursuant to this warranty or any other warranty implied by operation of any statute including the Competition and Consumer Act 2010 (Cth) (as amended) shall be limited to the cost of replacing defective Goods, the cost of obtaining equivalent Goods, or the cost of repairing the Goods at TS GLOBAL’s discretion provided that in all such cases any costs of dismantling and reassembly shall be borne by the Customer.

6.2 The warranty set out at clause 6.1 is subject to the following:

- a) the warranty applies for a period of 12 months commencing on the date of invoice of the Goods;
- b) the warranty does not apply to consumable components that are subject to normal wear and tear;
- c) the Customer must provide TS GLOBAL with either an invoice number or purchase order number referencing the defective Goods;

- d) the defects to the Goods must have arisen solely from faulty materials or workmanship; and
- e) the damage to the Goods must not arise from:
 - i. incorrect installation of the Goods contrary to the instructions contained within TS Global's Installation and Operation Manuals;
 - ii. improper adjustment, calibration or operation by the Customer;
 - iii. the use of accessories including consumables, hardware, or software which were not manufactured by or approved in writing by TS GLOBAL
 - iv. any contamination or leakages caused or induced by the Customer
 - v. any modifications of the Goods which was not authorised in writing by TS GLOBAL;
 - vi. any misuse of the Goods by the Customer;
 - vii. any use or operation of the Goods outside of the physical, electrical or environmental specifications of the Goods;
 - viii. inadequate or incorrect site preparation;
 - ix. inadequate or improper maintenance of the Goods; or
 - x. incorrect handling of the Goods.

6.3 If the Goods are not manufactured by TS GLOBAL the guarantee of the manufacturer of those Goods is accepted by the Customer and is the only guarantee given to the Customer in respect of the Goods. TS GLOBAL agrees to assign to the Customer on request made by the Customer the benefit of any warranty or entitlement to the Goods that the manufacturer has granted to TS GLOBAL under any contract or by implication or operation of law to the extent that the benefit of any warranty or entitlement is assignable.

6.4 Except as provided in these conditions, all express and implied warranties, guarantees and conditions under statute or general law as to merchantability, description, quality, suitability or fitness of the Goods for any purpose or as to design, assembly, installation, materials or workmanship or otherwise are expressly excluded. TS GLOBAL is not liable for physical or financial injury, loss or damage or for consequential loss or damage of any kind arising out of the supply, layout, assembly, installation or operation of the Goods or arising out of TS GLOBAL's negligence or in any way.

6.5 Nothing in these conditions shall be read or applied so as to exclude, restrict or modify or have the effect of excluding, restricting or modifying any condition, warranty, guarantee, right or remedy implied by law (including the Competition and Consumer Act 2010) and which by law cannot be excluded, restricted or modified.

This Warranty Statement must be read in conjunction with TS Global's Terms and Conditions of Sale which can be located on our website www.tsglobal.net.au

Section 2 – Safety Considerations, Precautions and Correct Storage

Before installing, operating, inspecting or maintaining this product, it is important to understand and follow all relevant site and statutory regulations.



Failure to follow site safety procedures exposes workers to uncontrolled hazards which can result in serious injury or in extreme cases, fatality.

Personal Protective Equipment (PPE) must be worn to control the foreseeable hazards associated with conveyor belts. Confined space, tensioning devices and heavy components create a worksite that may expose a worker to harm. Mechanical devices such as cranes or chain blocks can reduce exposure to harm.

Once hazards have been identified, the installer should undertake written Job Hazard Analysis according to site requirements. The installer must identify all hazards and apply appropriate controls before proceeding with the installation or servicing of this equipment.

There are installation, maintenance and operational activities involving both isolated and operating conveyors. Each has a safety protocol and it is your responsibility to be familiar with the sites requirements.

Operating Conveyors

There are two routine tasks that should be performed while the conveyor is running:

- Inspecting the performance and operation of the product
- Dynamic troubleshooting

Isolated Conveyors

The following activities are performed on isolated conveyors:

- Installation
- Parts replacement
- Repair
- Cleaning
- Adjustment

Correct Storage

Provided goods remain stored within boxes or on pallets wrapped with plastic, TS Global products can be stored outside in all weather conditions. If packaging is damaged or removed, TS Global recommends that the products be stored under cover and out of direct sunlight to minimise deterioration of any componentry.

Fig. 1a Main Components

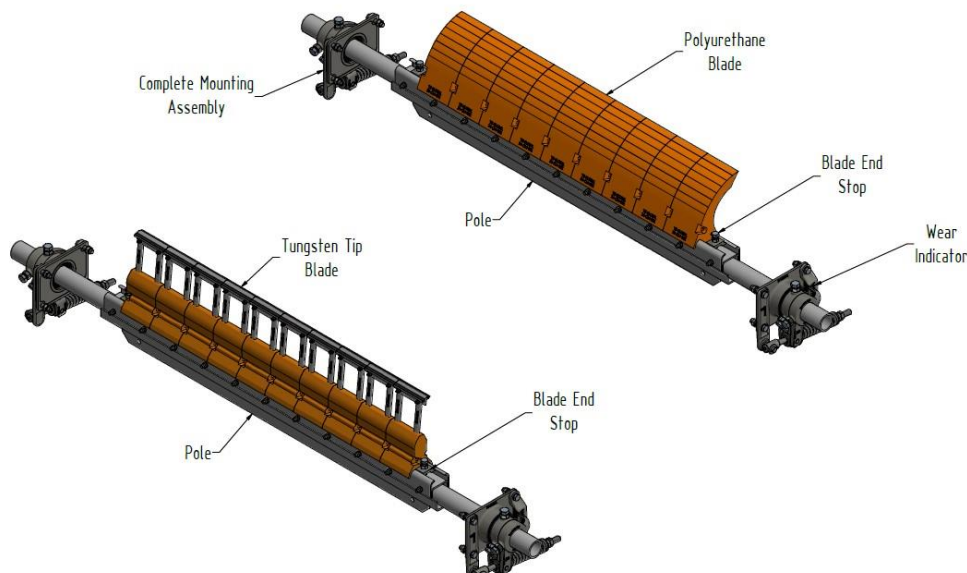

Section 3 – Installation Instructions

Checklist

- Check that the product size is correct for the conveyor to be installed on.
- Check the product and make sure all the parts have been supplied.
- Review the “Tools Needed” listed on page 7 of the Installation Instructions.

Before you begin:

- Familiarise yourself with the main components of this product (Fig. 1a).
- Determine the install location and check for clearances.
- Follow all safety precautions and site hot work procedures when using a cutting torch.
- If welding, protect all fastener threads and the belt from weld spatter.

Blade Profiles

TS global have two cleaner blade profiles for XHD primary cleaner-

- Poly blade
- Tungsten blade

Both blades can be interchanged on the pole however each profile is designed to operate in specific coordinate location. There are also several grades of poly blades available to cope with different product properties and conditions.

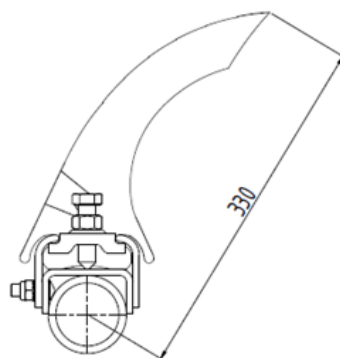

XHD Blade

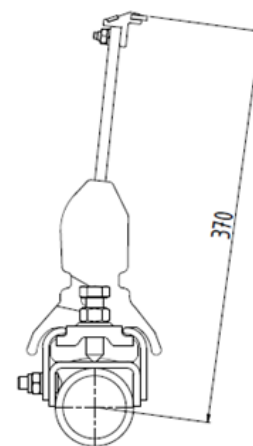

XHD Tungsten Tip Blade

To determine positioning of XHD cleaner pole, coordinates X and Y will need to be identified. Tungsten and Poly cleaners have different recommended mounting positions. The following table can be used:

Table 1

Pulley Diameter Over Belt – mm (Inches)	Poly Blade (0° Angle)			Tungsten Tip (15° Angle)		
	Dim X	Dim Y	Dim Z	Dim X	Dim Y	Dim Z
600 (23 5/8)	300 (11 13/16)	330 (13)	146 (5 3/4)	206 (8 1/8)	438 (17 1/4)	183 (7 3/16)
700 (27 9/16)	350 (13 13/16)	330 (13)	131 (5 3/16)	254 (10)	450 (17 11/16)	167 (6 9/16)
800 (31 1/2)	400 (15 3/4)	330 (13)	118 (4 1/4)	302 (11 7/8)	463 (18 1/4)	153 (6)
900 (35 7/16)	450 (17 3/4)	330 (13)	108 (3 15/16)	350 (13 13/16)	476 (18 3/4)	141 (5 9/16)
1000 (39 3/8)	500 (19 11/16)	330 (13)	99 (3 7/8)	399 (15 11/16)	489 (19 1/4)	131 (5 3/16)
1100 (43 5/16)	550 (21 11/16)	330 (13)	91 (3 9/16)	447 (17 5/8)	502 (19 3/4)	122 (4 13/16)
1200 (47 1/4)	600 (23 5/8)	330 (13)	85 (3 3/8)	495 (19 1/2)	515 (20 5/16)	115 (4 9/16)

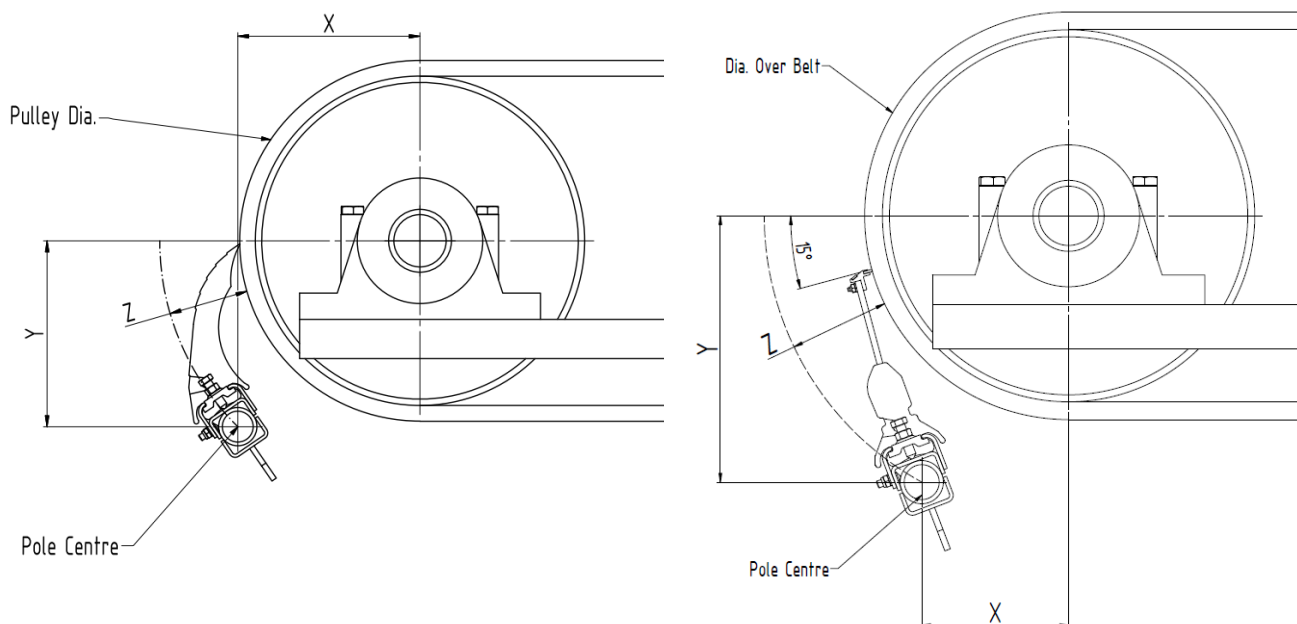

Note: standard pole coordinates will set cleaner poly blades to contact the belt on the pulley at the recommended 0 degrees on horizontal plane of the head pulley. For Tungsten Carbide blades the recommended installation coordinates place the tips on the pulley at 15 degrees below the horizontal centreline of the pulley. If, however standard coordinates cannot be used due to chute configuration use

Dim Z in previous table for best mounting position. The cleaner can be mounted in a range of 0-15 degrees below centre line. As the poly blades wear, they should contact the pulley within that 0-15 degree range. The tungsten blades do not have a wear range like the poly blades and are recommended to be installed at the 15-degree position to keep them out of the flow of product to protect them against impact and build up.

Alternatively, supply TS Global with the Pulley Diameter (including lagging) and the belt thickness and we will advise the recommended set up.

Suggested Tools Required for Installation

- Tape measure
- Marking Pen
- Level
- 2 x 150mm G Clamps
- 2 x 24mm Spanners
- 2 x 30mm spanners
- Cutting Torch and or Welder
- Grinder
- Magnet Drill
- Rota broach bit 18mm

Mounting Plates

1. Mark a horizontal reference line from the pulley centre.
2. Measure vertically down dimension Y and mark the horizontal pole centre line.
3. Measure out dimension X distance and mark the vertical pole centre line.

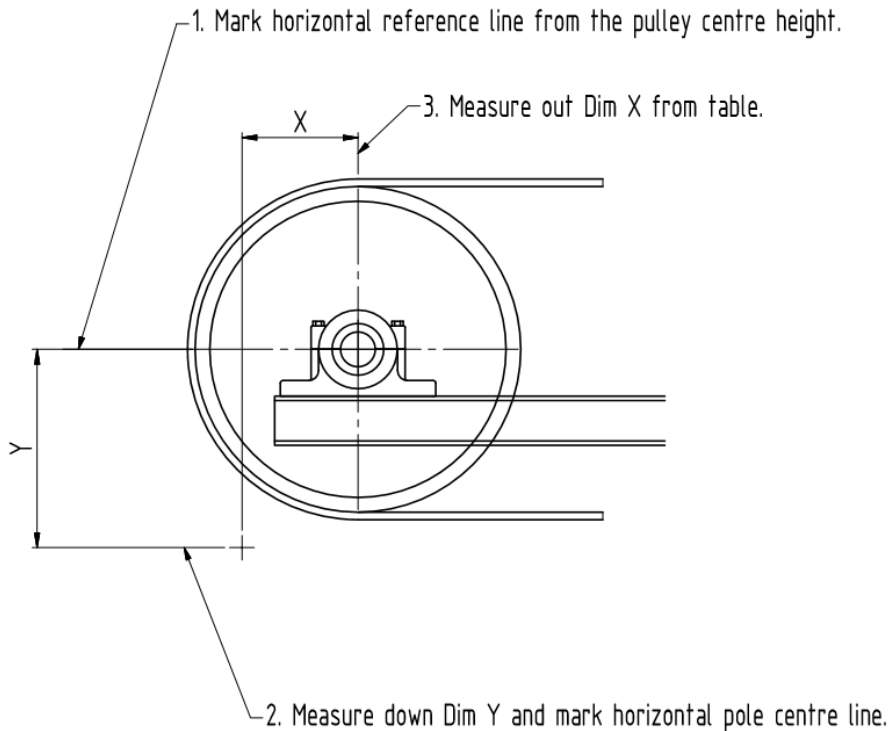

4. Where the horizontal and vertical pole centre lines intersect is the correct pole mounting centre.
5. The TUFF XHD end assembly comes as an assembled unit, remove the mounting plate.

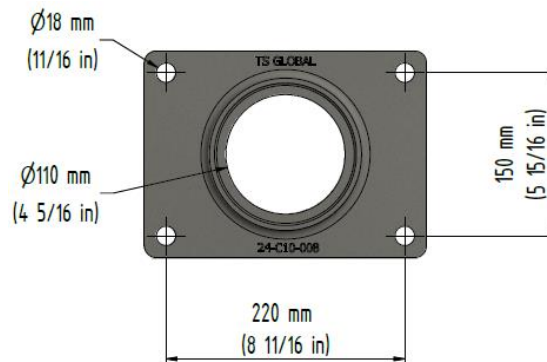

6. To select the desired mounting position, place the mounting plate over the pole centre line mark, confirming sufficient room for end assemblies.

NOTE: The mounting plate can be rotated to any suitable angle (as below).

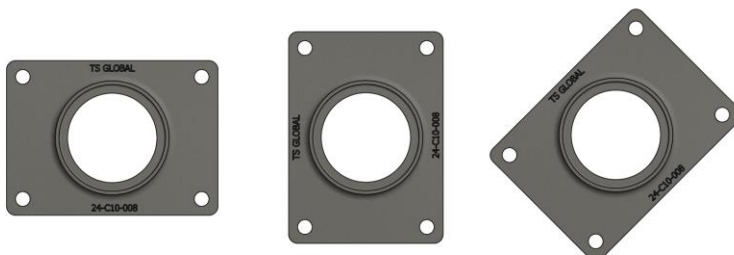

If the tensioner or mounting assemblies interfere with existing structure, it may be necessary to locate the cleaner pole centreline to another position on the "Radial Offset" (Dim Z). To do this use table 1.

If a suitable position can still not be obtained, a standoff or custom bracket may be required.

7. Mark out the 4 mounting bolt holes.
8. Mark out the chute cut outs required to install cleaner.

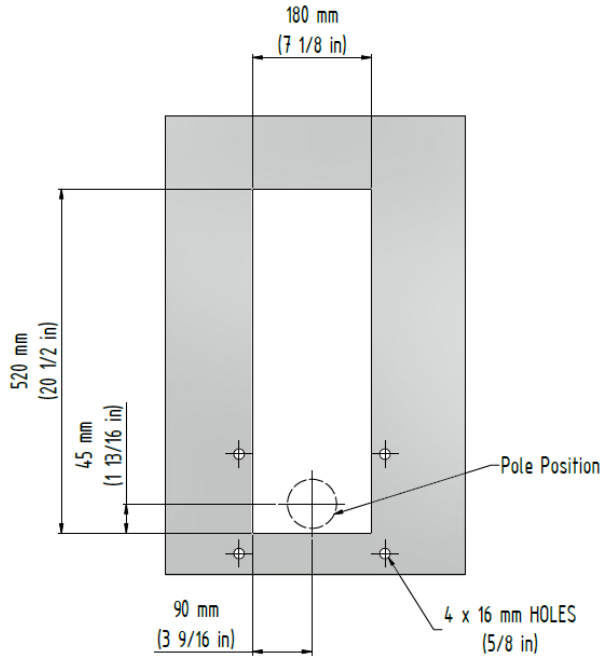

Operators side cut out

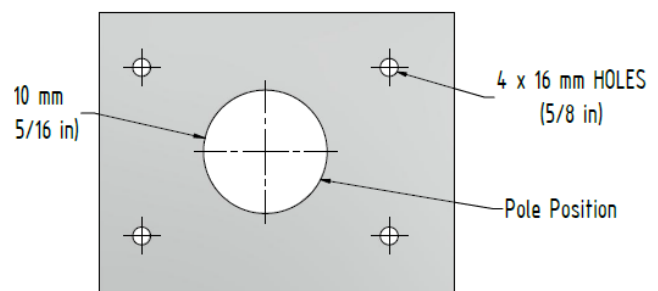

Far side cut out

9. Drill and make required cuts to chute.

Cleaner Installation

1. To install the cleaner, fit the mounting plate and bush to the far side chute wall.
2. Slide the cleaner through the operator's side chute cut out and into the far side mount.

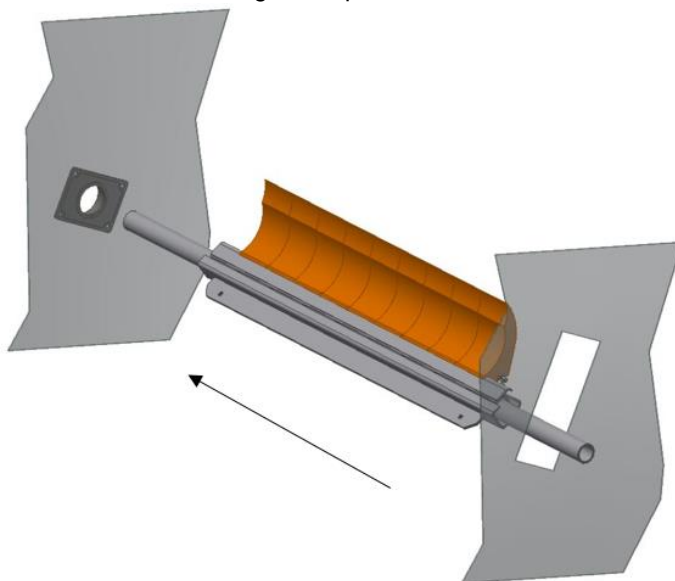

3. Centralise the cleaner and allow the pole to rotate so the tips are hanging down.
4. Fit operators side mounting plate and bush to the pole and fasten to chute wall.

Spring end assembly exploded view of components
 Air end assembly exploded view of components

For Spring Tensioned Cleaner

1. Fix operating arm and spring tensioning assembly up against the bush to both sides but do not tighten on the pole.

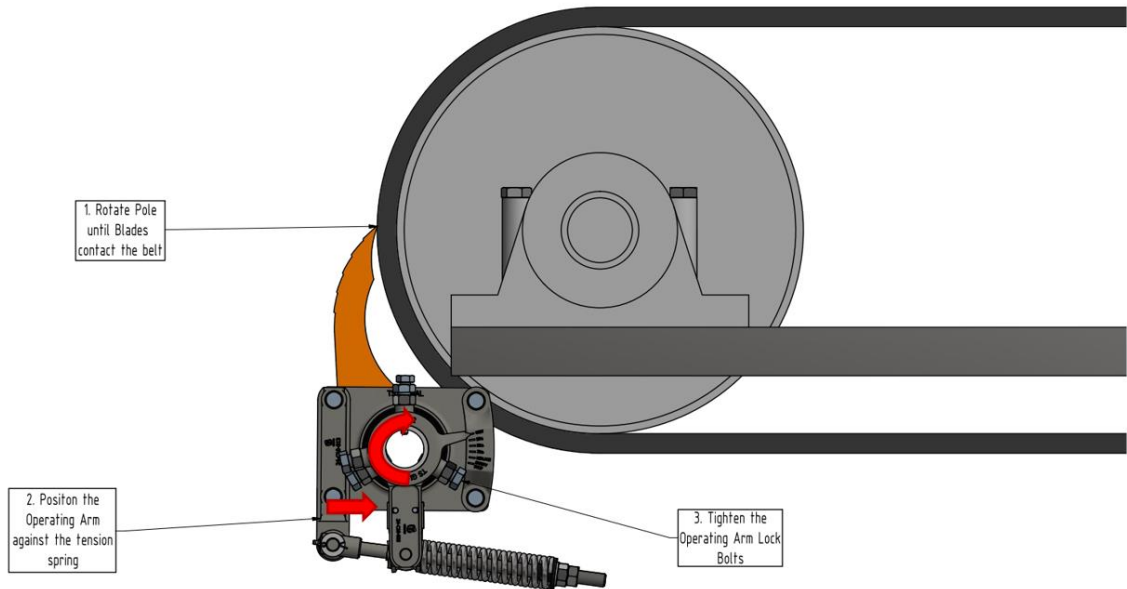

2. Using a pipe wrench or similar tool, rotate the cleaner pole until the blades are contacting the belt.
3. Rotate the operating arm back until retracted against the tension spring.
4. Tighten the operating arm locking bolts.
5. Repeat steps 3 and 4 on far side.
6. Adjust the wear indicator to provide an indication of blade wear visible from outside the chute.

Spring blade tensioning

7. Tension the cleaner by tightening the adjusting nuts until the tension spring is compressed to the correct length. Once adjusted, tighten the lock nut. Refer Spring tension table below.

Belt Width – mm (Inches)	Number of Blades	Spring Length	Approx. Number of Turns
450	2	172 (6 3/4)	1
600 (23 5/8)	3	172 (6 3/4)	1
750 (29 1/2)	4	169 (6 5/8)	1
900 (35 7/16)	5	162 (6 3/8)	1
1050 (41 5/16)	6	157 (6 3/16)	2
1200 (47 1/4)	6	157 (6 3/16)	2
1400 (55 1/8)	7	152 (6)	2
1500 (59 1/16)	8	177 (Twin Tensioners)	1
1600 (63)	9	168 (Twin Tensioners)	1
1800 (70 7/8)	1	162 (Twin Tensioners)	1
2000 (78 3/4)	1	157 (Twin Tensioners)	2
2200 (86 5/8)	1	152 (Twin Tensioners)	2
2400 (94 1/2)	1	152 (Twin Tensioners)	2

For Air Tensioned Cleaner

1. Fix operating arm and air tensioning assembly up against the bush to both sides but do not tighten on the pole.

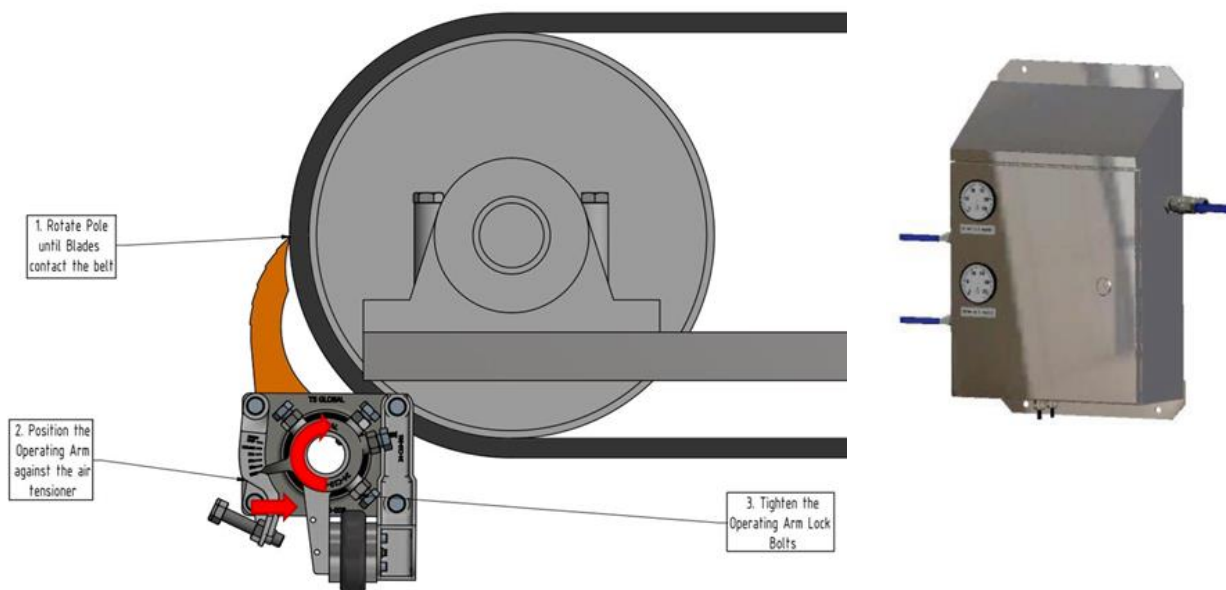

2. Using a pipe wrench or similar tool, rotate the cleaner pole until the blades are contacting the belt.
3. Rotate the operating arm back until retracted against the air tensioner.
4. Tighten the operating arm locking bolts.
5. Repeat steps 3 and 4 on far side
6. Adjust the wear indicator to provide an indication of blade wear visible from outside the chute.
7. Adjust the stop set screw to prevent the blade wearing past the maximum wear line position.

Air blade tension

Tension the cleaner by connecting the airlines. TS Global recommend the use of a TUFF Air Control Board to deliver clean filtered air and maintain correct pressure. Dual outlet control box shown above.

Belt Width	Number of Blades	Air Pressure	
		KPA	PSI
450 (17 ¹¹ / ₁₆)	2	55	8
600 (23 ⁵ / ₈)	3	69	1
750 (29 ¹ / ₂)	4	82	1
900 (35 ⁷ / ₁₆)	5	96	1
1050 (41 ⁵ / ₁₆)	6	110	1
1200 (47 ¹ / ₄)	6	124	1
1400 (55 ¹ / ₈)	7	138	2
1500 (59 ¹ / ₁₆)	8	82 (Twin Tensioners)	1
1600 (63)	9	96 (Twin Tensioners)	1
1800 (70 ⁷ / ₈)	10	96 (Twin Tensioners)	1
2000 (78 ³ / ₄)	11	110 (Twin Tensioners)	1
2200 (86 ⁵ / ₈)	12	124 (Twin Tensioners)	1
2400 (94 ¹ / ₂)	13	138 (Twin Tensioners)	2

Section 4 – Pre-Operation Checklist and Testing

Pre-Operation Checklist

- Recheck that all fasteners are tightened properly.
- Check blades are in full contact area on the belt.
- Check coordinates of cleaner pole.
- Be sure that all installation materials and tools have been removed from the belt and the conveyor area.
- Ensure any removed guarding has been returned into position.

Test Run the Conveyor

- Remove isolation.
- Run the conveyor for at least 15 minutes and inspect the product performance.
- Check all components for proper positioning and tensioning.
- Check cleaner pole for excessive vibration or material passing blades.
- Make adjustments as necessary. In some case this may require isolation of the conveyor.

NOTE: Observing the product when it is running and performing properly will help to detect problems. If vibration occurs or material passing blades refer to section 6.

Section 5 – Maintenance

TS Global products are designed to operate with a minimum maintenance, however, to maintain superior performance some service is required. When the product is installed, a regular maintenance program should be established. This program will ensure that the product operates at optimal efficiency and problems can be identified and rectified before reduction in performance occurs.

Routine Visual Inspection (Recommended every 4 weeks)

A visual inspection of the cleaner and belt can determine:

- If cleaner blades are in full contact with belt.
- If the belt looks clean and cleaner has correct tension.
- If the blades are worn out and need to be replaced.
- If there is damage to other cleaner components.
- If excess material is built up on the cleaner.
- If there is cover damage to the belt.
- If there is vibration of the cleaner.

If any of the above conditions exist, a determination should be made on when the conveyor can be stopped for maintenance.

Routine Physical Inspection (Recommended every 3 months)

When the conveyor is not in operation, undertake a physical inspection of the product to perform the following tasks:

- Clean material build-up off cleaner.
- Closely inspect the blades for wear and any damage and replace if needed.
- Ensure full contact of blades across belt.
- Inspect all fasteners for tightness and wear. Tighten or replace as needed.
- Replace any worn or damaged components.
- Ensure cleaner has correct tension.
- When maintenance tasks are completed, test run the conveyor to ensure the cleaner is performing correctly.

Blade Service Instructions

1. Prior to commencing blade replacement, isolate conveyor as per site regulations.
2. Release all tension on the cleaner blades.
3. Roll cleaner back slightly to gain clearance between blades and belt.
4. Remove blade end stop.
5. Use blade extraction tool to remove all worn blades.

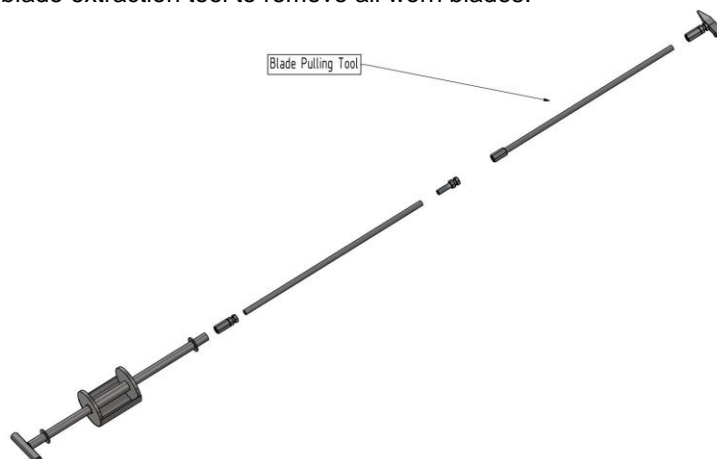

6. Check pole for straightness and wear.
7. Check all components for wear and replace as required.
8. Replace blades and end stop.
9. Adjust cleaner as detailed on page 10.
10. Test Run Cleaner:
 - i. Recheck that all fasteners are tightened properly.
 - ii. Check the blades are in contact with belt.
 - iii. Be sure that all materials and tools have been removed from the belt and the conveyor area.
 - iv. Remove isolation.
 - v. Run the conveyor for at least 15 minutes and inspect the cleaners performance
 - vi. Check all components for proper positioning.
 - vii. Adjust as necessary. In some cases, this may require isolation of the conveyor.

NOTE: Observing the product when it is running and performing properly will help to detect problems. If vibration occurs or material passing blades refer to section 6.

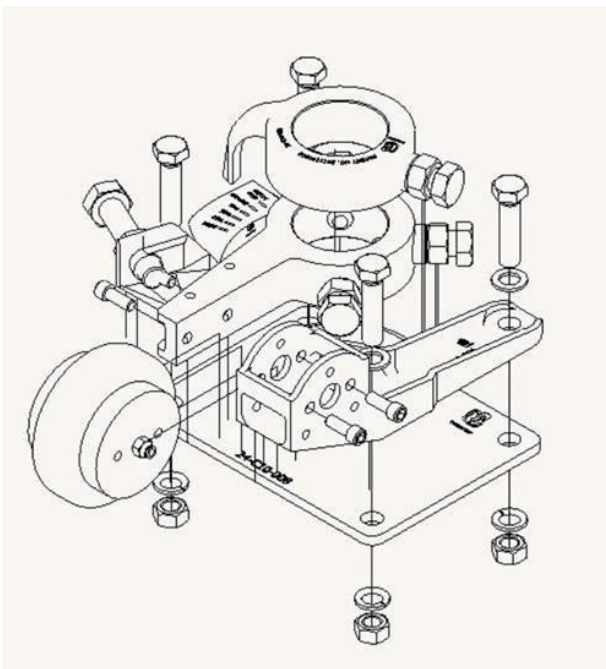

Air tensioned end assembly

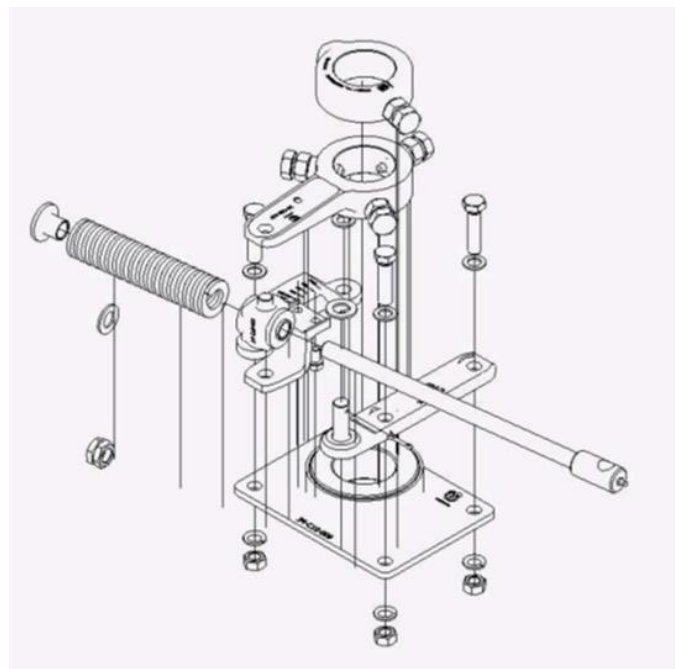

Spring Tensioned end assembly

Section 6 – Troubleshooting

Problem	Possible cause	Possible solution
Vibration	Cleaner pivots or mounting bolts loose	Ensure all locking nuts are tight
	Cleaner not set up correctly	Ensure cleaner set up properly (check pole position and coordinates)
	Dry belt	Consider low friction poly blades or water sprays to wet the belt where the belt runs without load for long periods
	Cleaner over tensioned	Ensure cleaner is correctly tensioned
	Cleaner under tensioned	Ensure cleaner is correctly tensioned
Material build up on cleaner	Cleaner not set up correctly	Ensure cleaner is set up properly (check pole position)
	Build up in chute	Ensure cleaner is not located too close to back of chute, allowing build up
	Excessive sticky material	Frequently clean unit of build-up. Introduce Spray Bar and Water Control Manifold
Thin Poly strip curling on top of blade	Heeling of the blade due to the pole too close to the pulley	Check coordinates of the pole is correct and move as required
Damaged belt cover	Cleaner over-tensioned	Check cleaner is correctly tensioned
	Cleaner blade damaged	Check blade for wear, replace where necessary
	Attack angle not correct	Ensure cleaner set up properly (check pole position and coordinates)
	Material built up in chute	Frequently clean unit of build up
Cleaner not conforming to belt	Cleaner not set up properly	Ensure cleaner set up properly (check pole position)
	Wear profile in belt cover	New blades will wear into belt profile if pole position is correct
Material passing cleaner	Cleaner not set up properly	Ensure cleaner set up properly (check pole position)
	Cleaner tension too low	Ensure cleaner is correctly tensioned
	Cleaner blades worn or damaged	Check blades for wear or damage, replace where necessary
	Belt deformed on pulley	Replace pulley lagging
	Wear profile in belt cover	New blades will wear into belt profile if pole position is correct

Section 7 – Replacement Parts

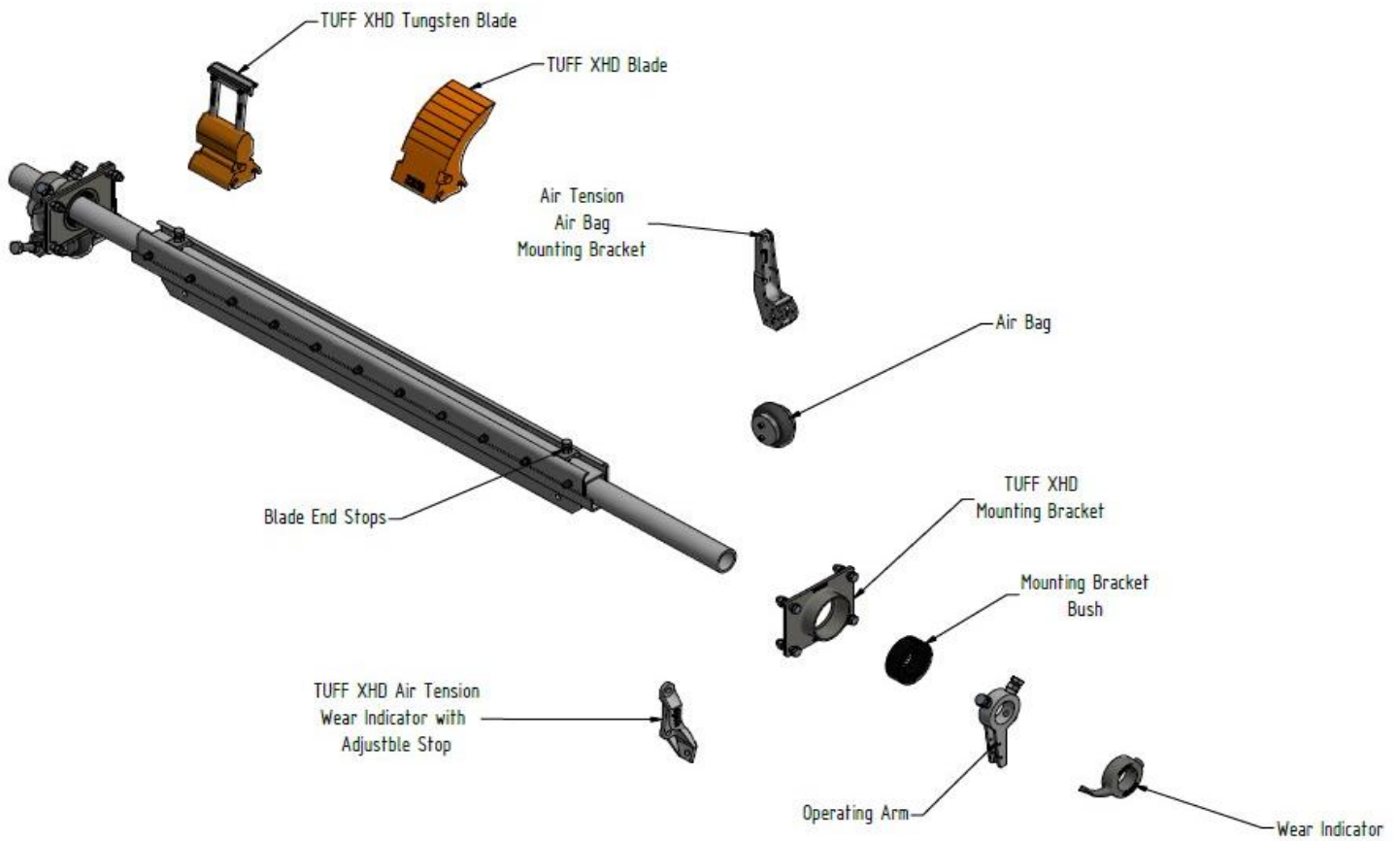
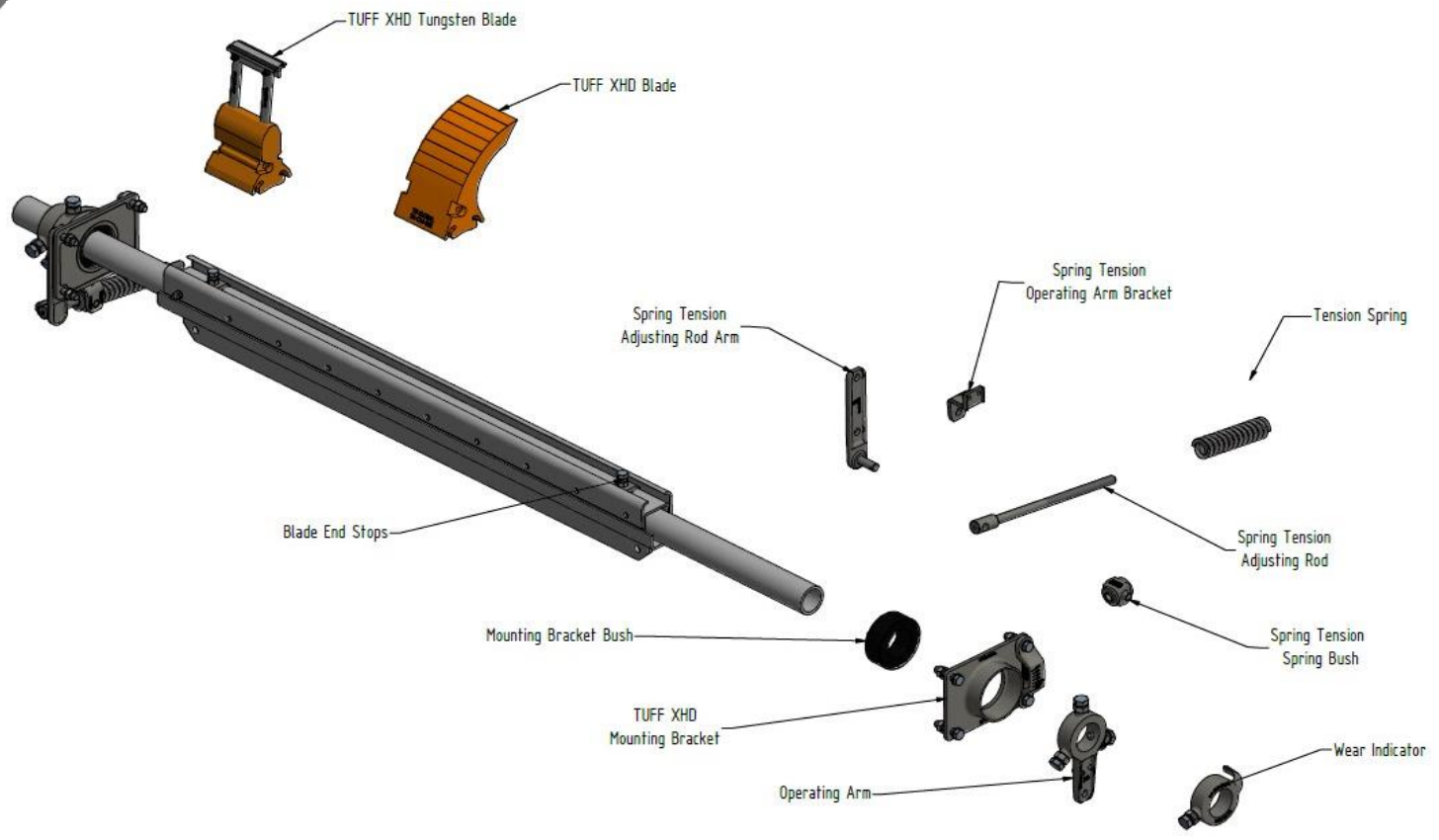

XHD Pole	
Description – mm (Inches)	Part Number
Tuff XHD pole 600 (23 ⁵ / ₈)	24-C11-020
Tuff XHD pole 750 (29 ¹ / ₂)	24-C11-021
Tuff XHD pole 900 (35 ⁷ / ₁₆)	24-C11-001
Tuff XHD pole 1050 (41 ⁵ / ₁₆)	24-C11-002
Tuff XHD pole 1200 (47 ¹ / ₄)	24-C11-003
Tuff XHD pole 1400 (55 ¹ / ₈)	24-C11-004
Tuff XHD pole 1500 (59 ¹ / ₁₆)	24-C11-005
Tuff XHD pole 1600 (63)	24-C11-006
Tuff XHD pole 1800 (70 ⁷ / ₈)	24-C11-007
Tuff XHD pole 2000 (78 ³ / ₄)	24-C11-008

XHD Tungsten Blade	
Description	Part Number
Tuff XHD Tungsten tip only	24-C14-018
Tuff XHD Tungsten blade body without tip	24-C14-019
Tuff XHD Tungsten blade complete with tip	24-C14-020

XHD Poly Blade	
Description	Part Number
Tuff XHD blade standard orange	24-C14-001
Tuff XHD blade FRAS black	24-C14-002
Tuff XHD blade ceramic blue	24-C14-003
Tuff XHD blade FRAS ceramic black	24-C14-004
Tuff XHD blade low friction ceramic yellow	24-C14-005
Tuff XHD blade low friction green	24-C14-007
Tuff XHD blade NG13 low friction red	24-C14-017

XHD End Assembly Complete	
Description	Part Number
TUFF XHD end assembly RH air tension down	24-A10-001
TUFF XHD end assembly RH air tension up	24-A10-002
TUFF XHD end assembly LH air tension down	24-A10-003
TUFF XHD end assembly LH air tension up	24-A10-004
TUFF XHD end assembly RH spring tension down	24-A10-006
TUFF XHD end assembly RH spring tension up	24-A10-007
TUFF XHD end assembly LH spring tension down	24-A10-008
TUFF XHD end assembly LH spring tension up	24-A10-009

XHD Components	
Description	Part Number
Tuff XHD air tension air bag mounting bracket	24-C10-001
Tuff XHD pole locking collar	24-SC-002
Tuff XHD air tension down wear indicator with adjustable stop LH	24-C10-003
Tuff XHD air tension down wear indicator with adjustable stop RH	24-C10-004
Tuff XHD air tension up wear indicator with adjustable stop LH	24-C10-005
Tuff XHD air tension up wear indicator with adjustable stop RH	24-C10-006
Tuff XHD blade stop casting supplied with bolt	24-C10-007
Tuff XHD mounting bracket	24-C10-008
Tuff XHD mounting bracket bush FRAS	24-C10-009
Tuff XHD mounting bracket off set	24-C10-010
Tuff XHD spring tension adjusting rod	24-C10-012
Tuff XHD spring tension adjusting rod arm	24-C10-013

Tuff XHD spring tension down wear indicator LH	24-C10-014
Tuff XHD spring tension down wear indicator RH	24-C10-015
Tuff XHD spring tension operating arm	24-C10-016
Tuff XHD spring tension spring	24-C10-017
Tuff XHD spring tension spring bush	24-C10-018
Tuff XHD spring tension thread protector bush	24-C10-019
Tuff XHD spring tension up wear indicator LH	24-C10-020
Tuff XHD spring tension up wear indicator RH	24-C10-021
Tuff XHD wear indicator arm with bolt	24-C10-022
Tuff XHD spring tension operating arm assembly	24-C10-023
Tuff XHD spring tension operating arm bracket	24-C10-024
Tuff XHD air bag operating arm with bolt	24-C10-025



TSGlobal

Conveyor & Polyurethane Specialists

DISTRIBUTED BY

PHONE 1300 418 298 • EMAIL sales@tsglobal.net.au • WEB www.tsglobal.net.au
WELSHPOOL WA • TOMAGO NSW • EMERALD QLD
ABN 30 603 644 748

