

Diagonal Plough

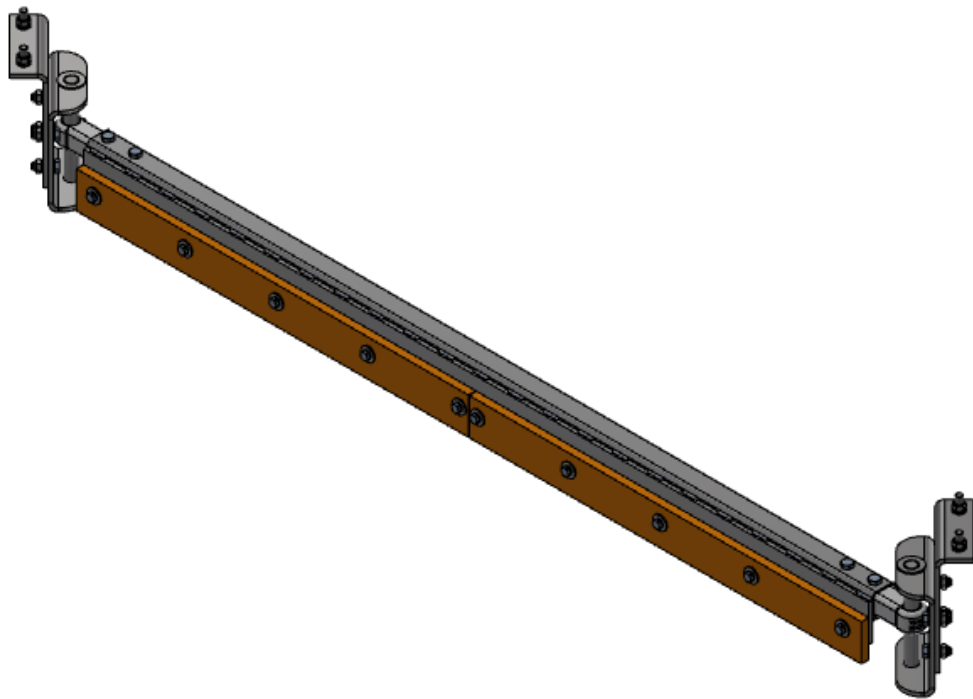

TSGlobal[®]
Leaders in Conveyor Products

Installation, Operation and Maintenance Manual

Contents

Section 1 – Important Information.....	3
General Information	3
User Benefits.....	3
Service Option	3
Warranty	3
Section 2 – Safety Considerations, Precautions and Correct Storage	5
Operating Conveyors.....	5
Isolated Conveyors	5
Correct Storage	5
Section 3 – Installation Instructions	6
Checklist.....	6
Suggested Tools Required for Installation	7
Install Mounting Assemblies	7
Section 4 – Pre Operation Checklist and Testing	9
Pre-Operation Checklist.....	9
Test Run the Conveyor.....	9
Section 5 – Maintenance	10
Routine Visual Inspection (Recommended every 4 weeks).....	10
Routine Physical Inspection (Recommended every 3 months).....	10
Blade Service Instructions.....	11
Section 6 – Troubleshooting	12
Section 7 – Replacement Parts	13

Section 1 – Important Information

General Information

TS Global is pleased that you have selected one of our products for your conveyor system.

This manual will assist in the understanding and operation of the product and allow it to perform at its maximum efficiency.

For safe and efficient operation, it is essential that the information and guidelines presented be properly understood and implemented. This manual will provide safety precautions, storage advice, installation instructions, maintenance procedures, recommended spares and troubleshooting tips.

If, however, you have any questions or problems that are not covered in this manual, please contact the nearest authorised distributor or visit our website. www.tsglobal.net.au

All persons directly responsible for the installation, operation and maintenance of this product should read this manual thoroughly. Whilst we have attempted to make the installation and service tasks as simple as possible, optimum performance from the product will require correct installation, regular inspections, adjustments and maintenance to maintain maximum efficiency.

User Benefits

Provided the correct installation and regular maintenance tasks are performed, our product will provide the following benefits to your operation:

- Increase conveyor availability and reliability.
- Reduced man-hour labour requirements.
- Lower maintenance costs.
- Increased service life.
- Reduction in Safety Hazards around conveyor.
- Reduction in Environmental Impact.

Service Option

This product is designed to be easily installed and serviced by your on-site personnel, however, if you would prefer a complete turn-key service, please contact TS Global for a list of your nearest distributors.

Warranty

The warranty provided by TS Global Pty Limited ("TS Global") is set out in the TS Global Terms and Conditions of Sale at clauses 6.1 to 6.5 inclusive. Those clauses are set out below: -

6.1 Subject to these conditions of sale, TS GLOBAL warrants that the Goods are free of defects both in material and workmanship and are of merchantable quality. The liability of TS GLOBAL pursuant to this warranty or any other warranty implied by operation of any statute including the Competition and Consumer Act 2010 (Cth) (as amended) shall be limited to the cost of replacing defective Goods, the cost of obtaining equivalent Goods, or the cost of repairing the Goods at TS GLOBAL's discretion provided that in all such cases any costs of dismantling and reassembly shall be borne by the Customer.

6.2 The warranty set out at clause 6.1 is subject to the following:

- a) the warranty applies for a period of 12 months commencing on the date of invoice of the Goods;
- b) the warranty does not apply to consumable components that are subject to normal wear and tear;
- c) the Customer must provide TS GLOBAL with either an invoice number or purchase order number referencing the defective Goods;

- d) the defects to the Goods must have arisen solely from faulty materials or workmanship; and
- e) the damage to the Goods must not arise from:
 - i. incorrect installation of the Goods contrary to the instructions contained within TS Global's Installation and Operation Manuals;
 - ii. improper adjustment, calibration or operation by the Customer;
 - iii. the use of accessories including consumables, hardware, or software which were not manufactured by or approved in writing by TS GLOBAL
 - iv. any contamination or leakages caused or induced by the Customer
 - v. any modifications of the Goods which was not authorised in writing by TS GLOBAL;
 - vi. any misuse of the Goods by the Customer;
 - vii. any use or operation of the Goods outside of the physical, electrical or environmental specifications of the Goods;
 - viii. inadequate or incorrect site preparation;
 - ix. inadequate or improper maintenance of the Goods; or
 - x. incorrect handling of the Goods.

6.3 If the Goods are not manufactured by TS GLOBAL the guarantee of the manufacturer of those Goods is accepted by the Customer and is the only guarantee given to the Customer in respect of the Goods. TS GLOBAL agrees to assign to the Customer on request made by the Customer the benefit of any warranty or entitlement to the Goods that the manufacturer has granted to TS GLOBAL under any contract or by implication or operation of law to the extent that the benefit of any warranty or entitlement is assignable.

6.4 Except as provided in these conditions, all express and implied warranties, guarantees and conditions under statute or general law as to merchantability, description, quality, suitability or fitness of the Goods for any purpose or as to design, assembly, installation, materials or workmanship or otherwise are expressly excluded. TS GLOBAL is not liable for physical or financial injury, loss or damage or for consequential loss or damage of any kind arising out of the supply, layout, assembly, installation or operation of the Goods or arising out of TS GLOBAL's negligence or in any way.

6.5 Nothing in these conditions shall be read or applied so as to exclude, restrict or modify or have the effect of excluding, restricting or modifying any condition, warranty, guarantee, right or remedy implied by law (including the Competition and Consumer Act 2010) and which by law cannot be excluded, restricted or modified.

This Warranty Statement must be read in conjunction with TS Global's Terms and Conditions of Sale which can be located on our website www.tsglobal.net.au

Section 2 – Safety Considerations, Precautions and Correct Storage

Before installing, operating, inspecting or maintaining this product, it is important to follow and understand all relevant site and statutory regulations. Please review the following safety information.



All statutory and site regulations must be followed before undertaking the following activities. Failure to follow site safety procedures exposes workers to uncontrolled hazards which can result in serious injury or in extreme cases, fatality.

Personal Protective Equipment (PPE) must be worn to control the foreseeable hazards associated with conveyor belts. Confined space, tensioning devices and heavy components create a worksite that may expose a worker to harm. Mechanical devices such as cranes or chain blocks can reduce exposure to harm.

Once hazards have been identified, the installer should undertake written Job Hazard Analysis according to site requirements. The installer must identify all hazards and apply appropriate controls before proceeding with the installation or servicing of this equipment.

There are installation, maintenance and operational activities involving both isolated and operating conveyors. Each has a safety protocol and it is your responsibility to be familiar with the site's requirements.

Operating Conveyors

There are two routine tasks that should be performed while the conveyor is running:

- Inspecting the performance and operation of the product.
- Dynamic troubleshooting.

Isolated Conveyors

The following activities are performed on isolated conveyors:

- Installation
- Parts replacement
- Repair
- Cleaning
- Adjustment

Correct Storage

Provided goods remain stored within boxes or on pallets wrapped with plastic, TS Global products can be stored outside in all weather conditions. If packaging is damaged or removed, TS Global recommends that the products be stored under cover and out of direct sunlight to minimise deterioration of any componentry.

Section 3 – Installation Instructions

Checklist

- Check that the product size is correct for the conveyor to be installed on.
- Check the product and make sure all the parts have been supplied.
- Review the “Tools Needed” listed on page 7 of the Installation instructions.
- Check the installation location: Is the install on open stringers requiring special mounting brackets?

Before you begin:

- Familiarise yourself with the main components of this product (Fig. 1a).
- Determine the install location and check for clearances (Figs. 1b).
- Follow all safety precautions and site hot work procedures when using a cutting torch.
- If welding, protect all fastener threads and the belt from weld spatter.

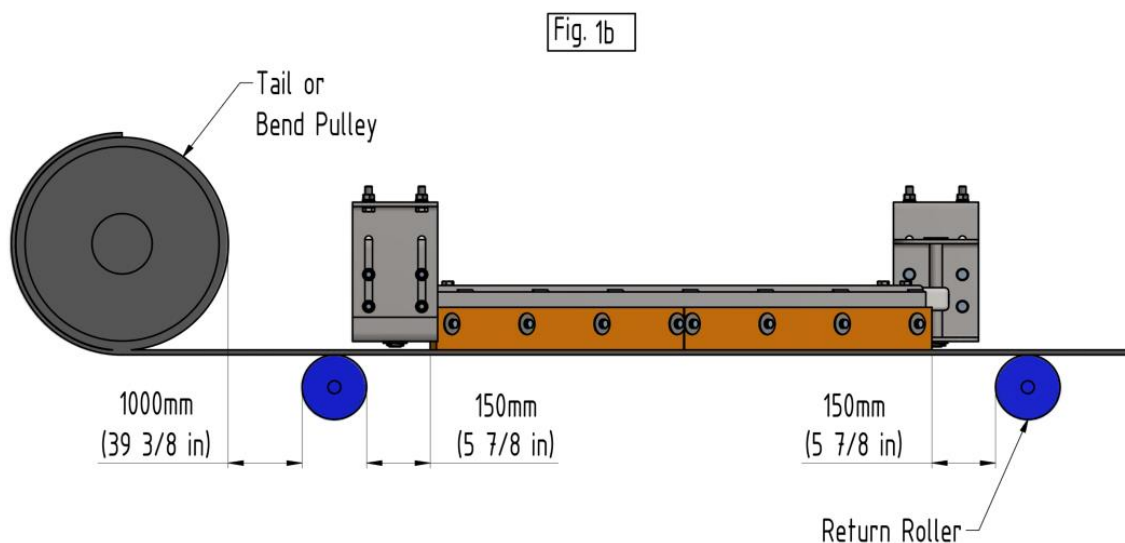
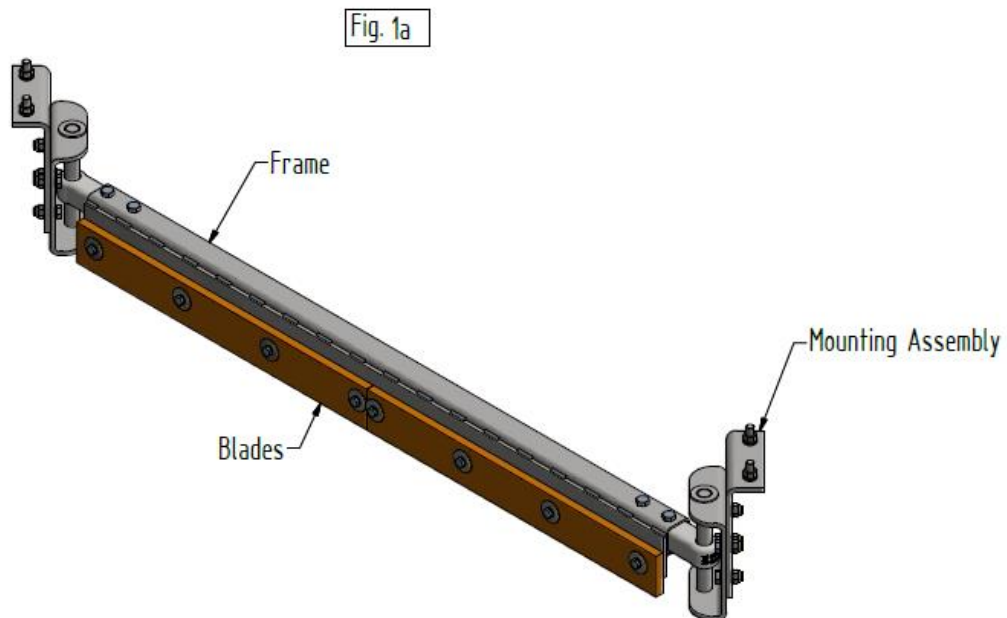

Suggested Tools Required for Installation

- Tape measure
- Marking Pen
- Level
- 2 x 150mm G Clamps
- 2 x 19mm Spanners
- 2 x 24mm Spanners
- Cutting Torch and or Welder
- Grinder
- Magnet drill
- Broach cutter 18mm

Install Mounting Assemblies

NOTE: The selected install position requires the belt to be flat and have sufficient access for maintenance.

1. Determine which side of the conveyor the material is to discharge. Diagonal Ploughs can be installed for a left- or right-handed discharge. Ideally the plough should be at a 45-degree angle and the blades need to be past the belt edges.
2. The plough mounting assemblies are adjustable allowing for the plough to self-adjust as the blade wears. This must be kept to a range of 215mm ($8 \frac{7}{16}$) - 320mm ($12 \frac{5}{8}$) from the top of the belt to the bottom of the stringer or structure.

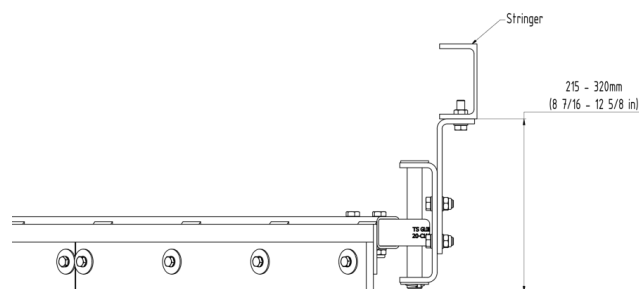

3. Once a suitable location is identified, mark out and drill the mounting holes in the stringer or structure using the image and table below.

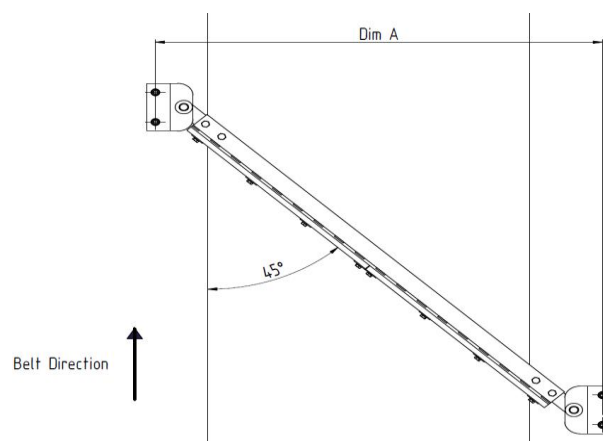

Belt Width mm (Inches)	600 ($23 \frac{5}{8}$) - 750 ($29 \frac{1}{2}$)	900 ($35 \frac{7}{16}$) - 1050 ($41 \frac{5}{16}$)	1200 ($47 \frac{1}{4}$) - 1500 ($59 \frac{1}{16}$)	1600 (63) - 1800 ($70 \frac{7}{8}$)
Dim A mm (Inches)	1105 ($43 \frac{1}{2}$) - 1250 ($49 \frac{3}{16}$)	1458 ($57 \frac{3}{8}$) - 1605 ($63 \frac{3}{16}$)	1812 ($71 \frac{5}{16}$) - 1960 ($77 \frac{3}{16}$)	2165 ($85 \frac{1}{4}$) - 2310 ($90 \frac{15}{16}$)

4. Loosen the height adjuster bolts.

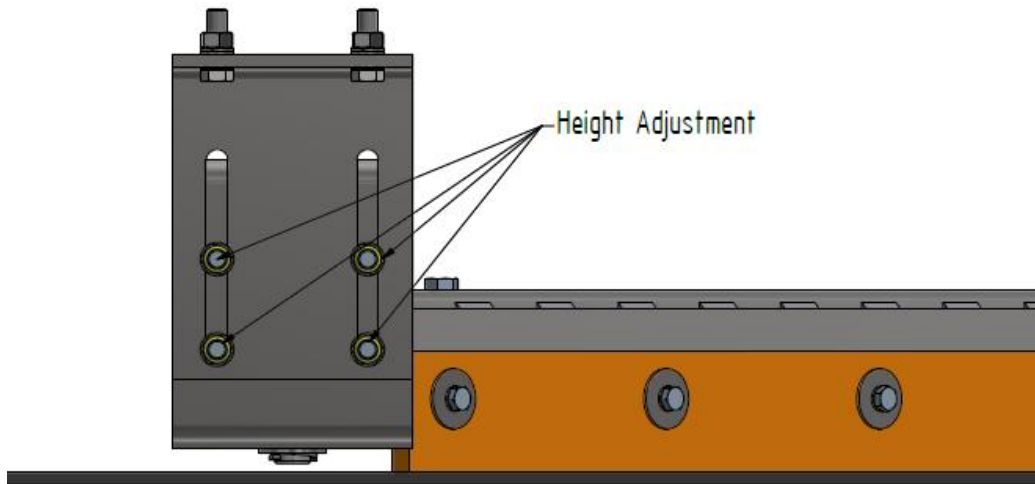

5. Place the plough onto the belt and bolt the mounting brackets to the stringer or structure.
6. Tighten the height adjuster bolts once a suitable height is identified ensuring there is free vertical movement to allow the plough to float up and down and blades to maintain contact with belt.

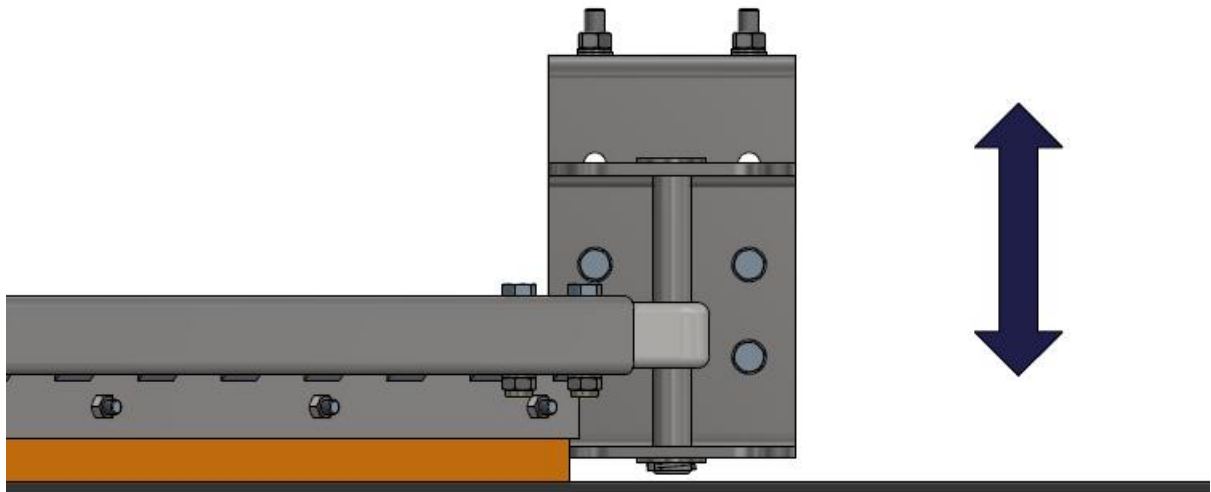

Section 4 – Pre-Operation Checklist and Testing

Pre-Operation Checklist

- Recheck that all fasteners are tightened properly.
- Check the product contact area on the belt.
- Be sure that all installation materials and tools have been removed from the belt and the conveyor area.

Test Run the Conveyor

- Remove isolation.
- Run the conveyor for at least 15 minutes and inspect the product performance.
- Check all components for proper positioning and blades in contact with belt.
- Make adjustments as necessary. In some case this may require isolation of the conveyor.

NOTE: Observing the product when it is running and performing properly will help to detect problems. If vibration occurs refer to Section 6.

Section 5 – Maintenance

TS Global products are designed to operate with a minimum maintenance, however, to maintain superior performance some service is required. When the product is installed, a regular maintenance program should be established. This program will ensure that the product operates at optimal efficiency and problems can be identified and rectified before reduction in performance occurs.

Routine Visual Inspection (Recommended every 4 weeks)

A visual inspection of the plough and belt can determine:

- If plough blade is in full contact with belt.
- If the belt looks clean or if there are areas that are dirty.
- If the blades are worn out and need to be replaced.
- If there is damage to other plough components.
- If fugitive material is built up on the plough.
- If there is cover damage to the belt.
- If there is vibration of the plough on the belt

If any of the above conditions exist, a determination should be made on when the conveyor can be stopped for maintenance.

Routine Physical Inspection (Recommended every 3 months)

When the conveyor is not in operation and isolated, undertake a physical inspection of the product to perform the following tasks:

- Clean material build-up off of the plough blade and frame.
- Closely inspect the blades for wear and any damage and replace if needed.
- Ensure full blade to belt contact.
- Inspect all fasteners for tightness and wear. Tighten or replace as needed.
- Replace any worn or damaged components.
- When maintenance tasks are completed, test run the conveyor to ensure the plough is performing correctly.

Blade Service Instructions

1. Prior to commencing blade replacement, isolate conveyor as per site regulations.
2. Remove blade fastening bolts, spring washers and flat washers.
3. Remove blade.

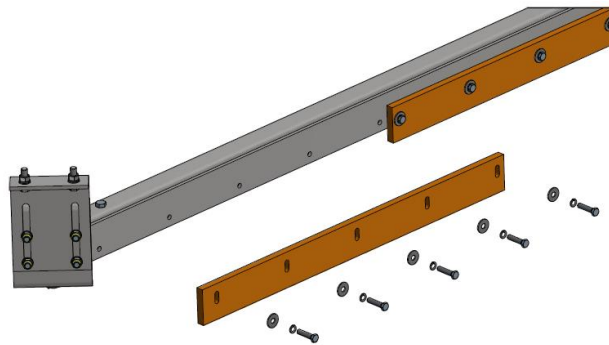

4. Replace blades.
5. Ensure plough blades are contacting entire belt surface.
6. Test run plough:
 - i. Recheck that all fasteners are tightened properly.
 - ii. Check the blade contact area on the belt.
 - iii. Be sure that all materials and tools have been removed from the belt and the conveyor area.
 - iv. Remove isolation.
 - v. Run the conveyor for at least 15 minutes and inspect the plough performance.
 - vi. Check all components for proper positioning.
 - vii. Make adjustments as necessary. In some cases this may require isolation of the conveyor.

NOTE: Observing the product when it is running and performing properly will help to detect problems. If vibration occurs refer to Section 6.

Section 6 – Troubleshooting

Problem	Possible Cause	Possible Solution
Material building up on plough	Angle of blade is insufficient	Check angle and set at 45 degrees
Material passing by the plough	Blades worn	Replace blades
	Insufficient blade coverage	Check angle set at 45 degrees Check correct plough has been installed
	Belt worn or damaged	Repair or replace belt
	Mechanical splice damage	Repair or replace splice
Vibration	Incorrect installation	Check angle set at 45 degrees
	Belt damaged	Repair or replace belt
	Loose or worn components	Tighten or replace components

Section 7 – Replacement Parts

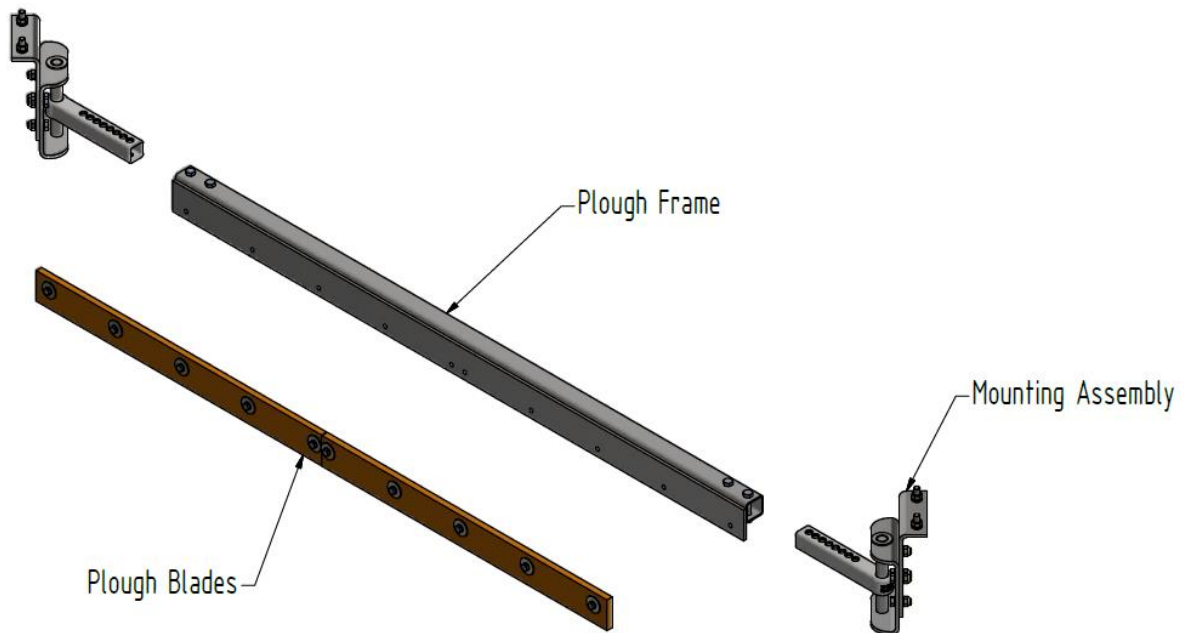

Diagonal Plough Frame and Mounting Assembly	
Description – mm (Inches)	Part Number
Diagonal Pole Frame 600 (70 7/8) -750 (29 1/2)	20-C18-001
Diagonal Pole Frame 900 (35 7/16) -1050 (41 5/16)	20-C18-002
Diagonal Pole Frame 1200 (47 1/4) -1500 (59 1/16)	20-C18-003
Diagonal Pole Frame 1600 (47) -1800 (70 7/8)	20-C18-004
Mounting Assembly	20-A10-001

Diagonal Plough Blades		
Description – mm (Inches)	Diagonal Blades	Diagonal Blades FRAS
Diagonal Plough Blade (70 7/8) -750 (29 1/2)	20-C14-001	20-C15-001
Diagonal Plough Blade 900 (35 7/16) -1050 (41 5/16)	20-C14-002	20-C15-002
Diagonal Plough Blade 1200 (47 1/4) -1500 (59 1/16)	20-C14-003	20-C15-003
Diagonal Plough Blade 1600 (47) -1800 (70 7/8)	20-C14-004	20-C15-004



TSGlobal[®]

Leaders in Conveyor Products

DISTRIBUTED BY