

# H Polyurethane Belt Cleaner

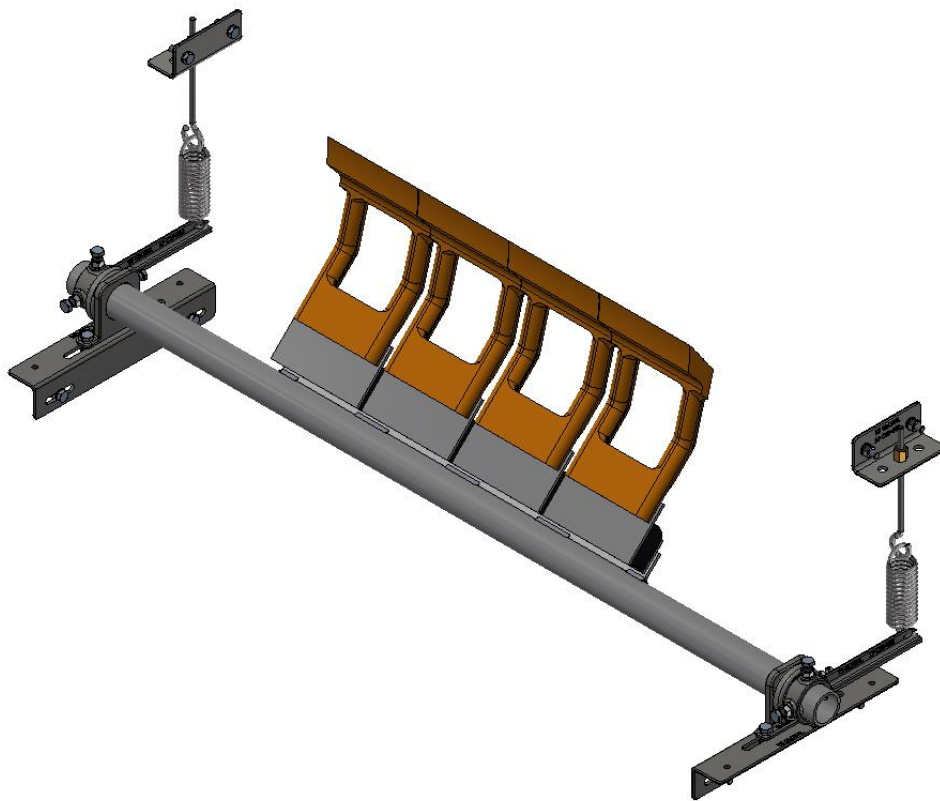

**TSGlobal**<sup>®</sup>  
Leaders in Conveyor Products

Installation, Operation and Maintenance Manual

## Contents

Section 1 – Important Information .....	3
General Information .....	3
User Benefits.....	3
Service Option.....	3
Warranty .....	3
Section 2 – Safety Considerations, Precautions and Correct Storage .....	5
Operating Conveyors .....	5
Isolated Conveyors.....	5
Correct Storage .....	5
Section 3 – Installation Instructions.....	6
Checklist .....	6
Suggested Tools Required for Installation .....	8
Install Mounting Assemblies .....	8
Mounting Bracket and Pivot Mounts.....	9
Cleaner Installation .....	10
Pole Adjustment and Blade Tension .....	12
Section 4 – Pre Operation Checklist and Testing .....	13
Pre-Operation Checklist .....	13
Test Run the Conveyor.....	13
Section 5 – Maintenance .....	14
Routine Visual Inspection (Recommended every 4 weeks).....	14
Routine Physical Inspection (Recommended every 3 months) .....	14
Blade and Cushion Service Instructions .....	15
Pre-Operation Checklist .....	15
Test Run the Conveyor.....	15
Section 6 – Troubleshooting .....	16
Section 7 – Replacement Parts .....	17

## Section 1 – Important Information

### General Information

TS Global is pleased that you have selected one of our products for your conveyor system.

This manual will assist in the understanding and operation of the product allowing it to perform at its maximum efficiency.

For safe and efficient operation, it is essential that the information and guidelines presented in this manual are understood and implemented. This manual will provide safety precautions, storage advice, installation instructions, maintenance procedures, recommended spares and troubleshooting tips.

If, however, you have any questions or problems that are not covered in this manual, please contact the nearest authorised distributor or visit our website, [www.tsglobal.net.au](http://www.tsglobal.net.au)

All persons directly responsible for the installation, operation and maintenance of this product should read this manual thoroughly. Whilst we have attempted to make the installation and service tasks as simple as possible the product will require correct installation, regular inspections, adjustments and maintenance to maintain maximum efficiency.

### User Benefits

Ensuring the correct installation and regular maintenance tasks are performed, our product will provide the following benefits to your operation:

- Increased conveyor availability and reliability
- Reduced man-hour labour requirements
- Lower maintenance costs
- Increased service life for the cleaner and other conveyor components
- Reduction in Safety Hazards around conveyor
- Reduction in Environmental Impact

### Service Option

This product is designed to be easily installed and serviced by your on-site personnel, however, if you would prefer a complete turn-key service, please contact TS Global for a list of your nearest distributors/ service providers.

### Warranty

The warranty provided by TS Global Pty Limited ("TS Global") is set out in the TS Global Terms and Conditions of Sale at clauses 6.1 to 6.5 inclusive. Those clauses are set out below: -

**6.1** Subject to these conditions of sale, TS GLOBAL warrants that the Goods are free of defects both in material and workmanship and are of merchantable quality. The liability of TS GLOBAL pursuant to this warranty or any other warranty implied by operation of any statute including the Competition and Consumer Act 2010 (Cth) (as amended) shall be limited to the cost of replacing defective Goods, the cost of obtaining equivalent Goods, or the cost of repairing the Goods at TS GLOBAL's discretion provided that in all such cases any costs of dismantling and reassembly shall be borne by the Customer.

**6.2** The warranty set out at clause 6.1 is subject to the following:

- a) the warranty applies for a period of 12 months commencing on the date of invoice of the Goods;
- b) the warranty does not apply to consumable components that are subject to normal wear and tear;
- c) the Customer must provide TS GLOBAL with either an invoice number or purchase order number referencing the defective Goods;

- d) the defects to the Goods must have arisen solely from faulty materials or workmanship; and
- e) the damage to the Goods must not arise from:
  - i. incorrect installation of the Goods contrary to the instructions contained within TS Global's Installation and Operation Manuals;
  - ii. improper adjustment, calibration or operation by the Customer;
  - iii. the use of accessories including consumables, hardware, or software which were not manufactured by or approved in writing by TS GLOBAL
  - iv. any contamination or leakages caused or induced by the Customer
  - v. any modifications of the Goods which was not authorised in writing by TS GLOBAL;
  - vi. any misuse of the Goods by the Customer;
  - vii. any use or operation of the Goods outside of the physical, electrical or environmental specifications of the Goods;
  - viii. inadequate or incorrect site preparation;
  - ix. inadequate or improper maintenance of the Goods; or
  - x. incorrect handling of the Goods.

**6.3** If the Goods are not manufactured by TS GLOBAL the guarantee of the manufacturer of those Goods is accepted by the Customer and is the only guarantee given to the Customer in respect of the Goods. TS GLOBAL agrees to assign to the Customer on request made by the Customer the benefit of any warranty or entitlement to the Goods that the manufacturer has granted to TS GLOBAL under any contract or by implication or operation of law to the extent that the benefit of any warranty or entitlement is assignable.

**6.4** Except as provided in these conditions, all express and implied warranties, guarantees and conditions under statute or general law as to merchantability, description, quality, suitability or fitness of the Goods for any purpose or as to design, assembly, installation, materials or workmanship or otherwise are expressly excluded. TS GLOBAL is not liable for physical or financial injury, loss or damage or for consequential loss or damage of any kind arising out of the supply, layout, assembly, installation or operation of the Goods or arising out of TS GLOBAL's negligence or in any way.

**6.5** Nothing in these conditions shall be read or applied so as to exclude, restrict or modify or have the effect of excluding, restricting or modifying any condition, warranty, guarantee, right or remedy implied by law (including the Competition and Consumer Act 2010) and which by law cannot be excluded, restricted or modified.

This Warranty Statement must be read in conjunction with TS Global's Terms and Conditions of Sale which can be located on our website [www.tsglobal.net.au](http://www.tsglobal.net.au)

## Section 2 – Safety Considerations, Precautions and Correct Storage

Before installing, operating, inspecting or maintaining this product, it is important to follow and understand all relevant site and statutory regulations. Please review the following safety information.



All statutory and site regulations must be followed before undertaking the following activities. Failure to follow site safety procedures exposes workers to uncontrolled hazards which can result in serious injury or in extreme cases, fatality.

Personal Protective Equipment (PPE) must be worn to control the foreseeable hazards associated with conveyor belts. Confined space, tensioning devices and heavy components create a worksite that may expose a worker to harm. Mechanical devices such as cranes or chain blocks can reduce exposure to harm.

Once hazards have been identified, the installer should undertake written Job Hazard Analysis according to site requirements. The installer must identify all hazards and apply appropriate controls before proceeding with the installation or servicing of this equipment.

There are installation, maintenance and operational activities involving both isolated and operating conveyors. Each has a safety protocol and it is your responsibility to be familiar with the site requirements.

### Operating Conveyors

There are two routine tasks that should be performed while the conveyor is running:

- Inspecting the performance and operation of the product
- Dynamic troubleshooting

### Isolated Conveyors

The following activities are performed on isolated conveyors:

- Installation
- Parts replacement
- Repair
- Cleaning

### Correct Storage

Provided goods remain stored within boxes or on pallets wrapped with plastic, TS Global products can be stored outside in all weather conditions. If packaging is damaged or removed, TS Global recommends that the products be stored under cover and out of direct sunlight to minimise deterioration of any componentry.

## Section 3 – Installation Instructions

### Checklist

- Check that the product size is correct for the conveyor to be installed on
- Check cleaner arm size is suitable for pulley diameter – refer to table below
- Check the product and make sure all the parts have been supplied
- Review the “Tools Needed” listed on page 8 of the Installation instructions
- Check the installation location: will the cleaner have clearance inside chute

### Before you begin:

- Familiarise yourself with the main components of this product (Fig. 1a)
- Determine the install location and check for clearances
- Follow all safety precautions and site hot work procedures (As required)
- Protect all fastener threads and the belt from weld spatter

**Note:** TS Global belt cleaners have been designed to be flexible in installation. In the event that conveyor head chute or structure needs to be modified, seek engineering approval from your site contact, prior to undertaking modification.

Fig. 1a

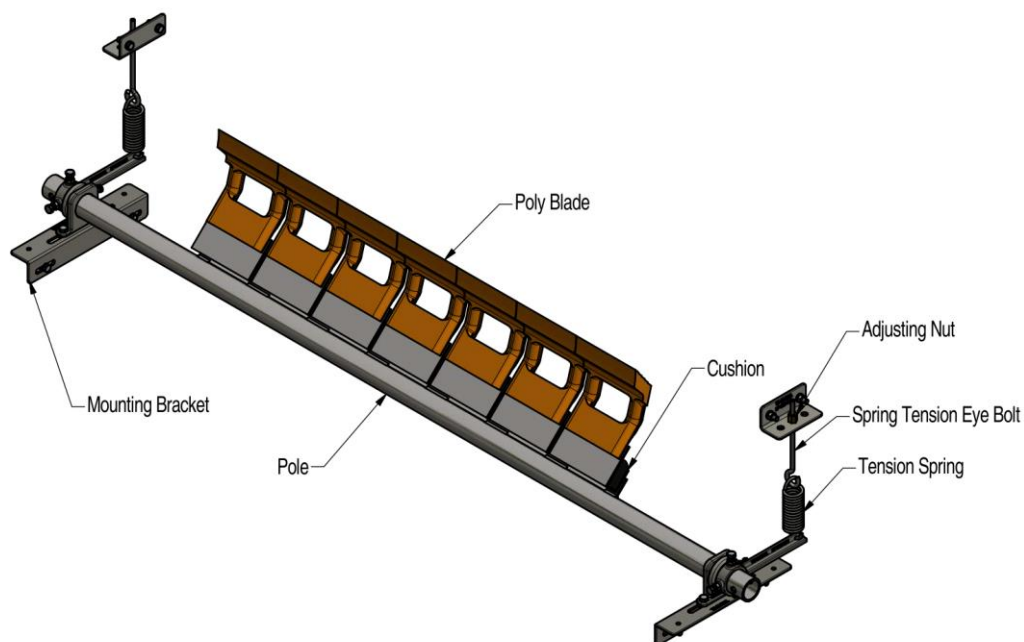

Use table to determine recommended polyurethane arm size.

Pulley diameter including lagging & belt thickness	Recommended arm size
250mm to 500mm	SS
500mm to 800mm	S
800mm to 1000mm	M
1000mm to 1200mm	L

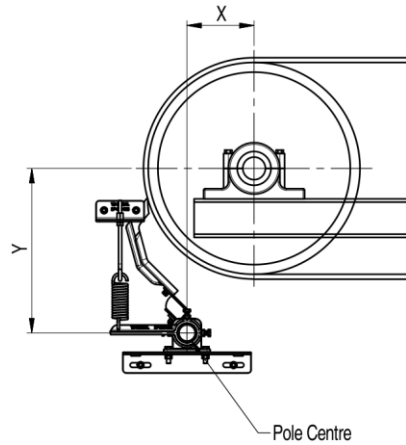

### TS Global Reference Chart

Pole Dia		48 Poles		60 Poles		73 Poles	
Arm size	Pulley Dia	Dim X	Dim Y	Dim X	Dim Y	Dim X	Dim Y
SS	250	51	304	46	308	42	312
	300	75	310	70	315	66	319
	350	90	316	95	321	90	325
	400	123	323	119	328	114	332
	450	147	329	143	334	138	338
S	500	171	336	167	340	162	345
	500	146	392	142	396	138	401
	600	195	405	190	409	186	414
	700	243	418	238	422	235	427
	800	291	431	286	435	282	440
M	800	274	476	270	481	265	485
	900	322	489	319	494	313	498
	1000	370	502	366	507	361	511
L	1000	349	524	345	528	340	533
	1100	397	537	393	541	388	546
	1200	445	549	441	554	436	559

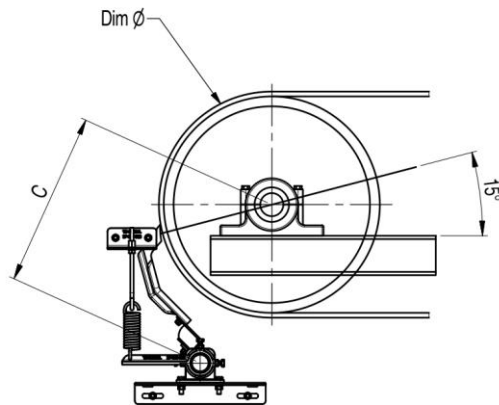

Alternatively, supply TS Global with the Pulley Diameter (including lagging) and the belt thickness and we will advise the recommended set up or alternatives.

### Suggested Tools Required for Installation

- Tape measure
- Marking Pen
- Level
- 2 x 150mm G Clamps
- 2 x 13mm spanners
- 2 x 17mm spanners
- 2 x 19mm Spanners
- 2 x 24mm Spanners (HD mounting)
- Cutting Torch and or Welder
- Grinder
- Drill
- Various drill bits up to 13mm

### Install Mounting Assemblies

1. Mark a horizontal reference line from the pulley centre.
2. Measure vertically down dimension Y and mark the horizontal pole centre line.
3. Measure out dimension X distance and mark the vertical pole centre line.
4. Where the horizontal and vertical pole centre lines intersect is the correct pole mounting centre.

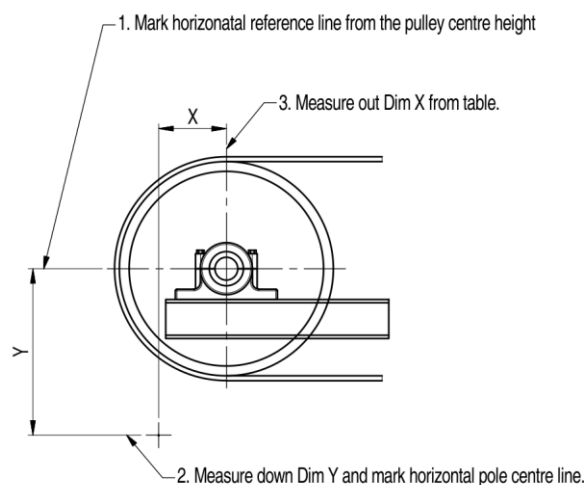

## Mounting Bracket and Pivot Mounts

1. In most applications, the standard mounting brackets will have adequate room to fit on the structure with no cutting.
2. Locate the pivots in the centre of the mounting brackets and nip up only. This will allow adjustment of the X dimension for fine tuning the blade attack angle.

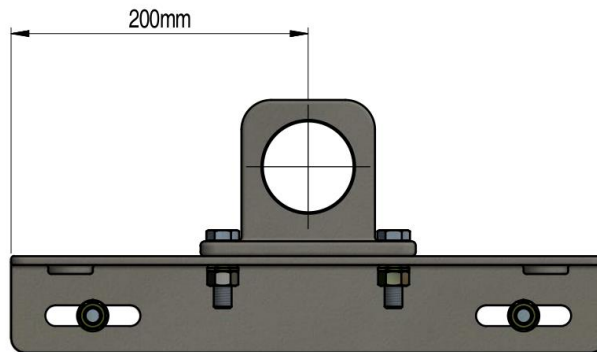

3. Confirm diameter of cleaner pole and utilising below table, mark a second horizontal line at dim A below the existing pole horizontal centre line.

Pole dia	Dim A
48mm	50mm
60mm	60mm
73mm	65mm

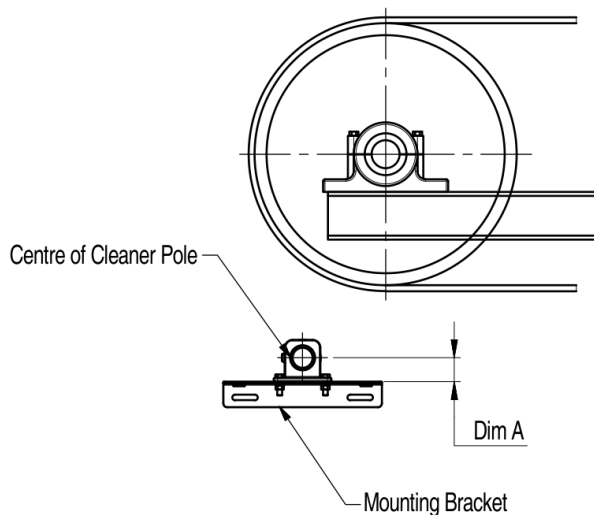

4. Clamp the mounting bracket into a horizontal position with 150mm clamps as per the sketch below. Recheck mounting position before proceeding.
5. Weld or bolt the mounting bracket into position and repeat for the opposite side.
6. Remove the operator's side pivot mount to allow the pole installation.

- If installing into a chute, access and maintenance cut outs will be required.

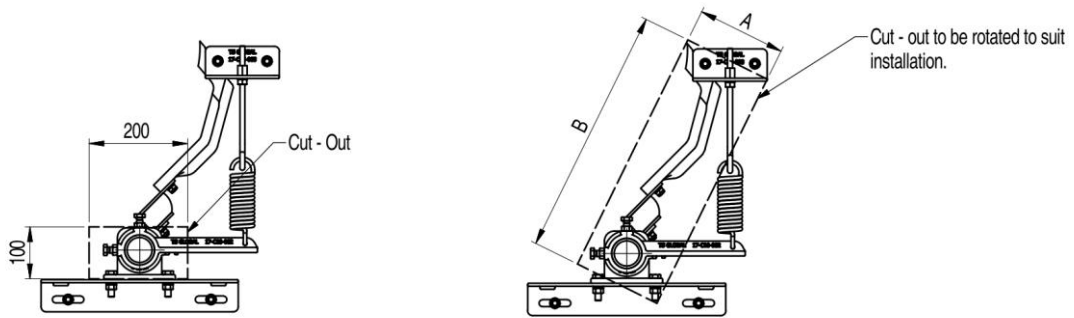

**Far side cut out**

**Operators side cut out**

Arm Size	Operator side cut out DIM A mm	Operator side cut out out DIM B mm
SS	170	370
S	170	420
M	170	470
L	170	500

### Cleaner Installation

- To install the cleaner, slide it through the chute cut outs and into the far side pivot mount. Allow the pole to rotate so the poly blades are hanging down.

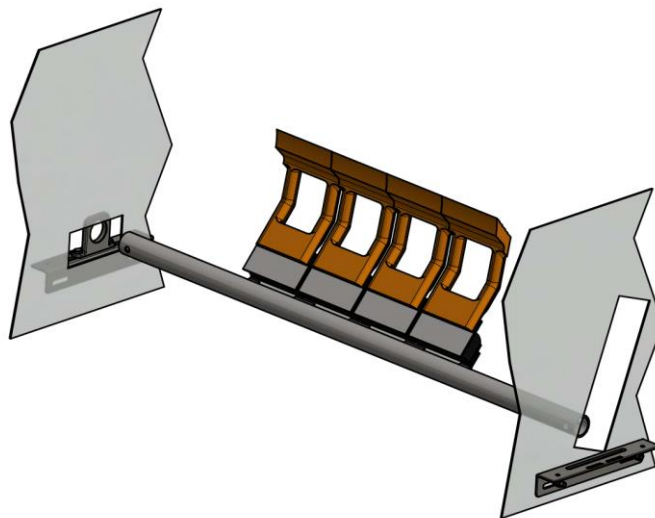

- Slide operator side pivot mount onto cleaner pole and position in centre of cleaner mounting bracket.
- Install pivot mounting bolts, however do not tighten.
- Fit both collars arms to cleaner pole, however do not tighten.

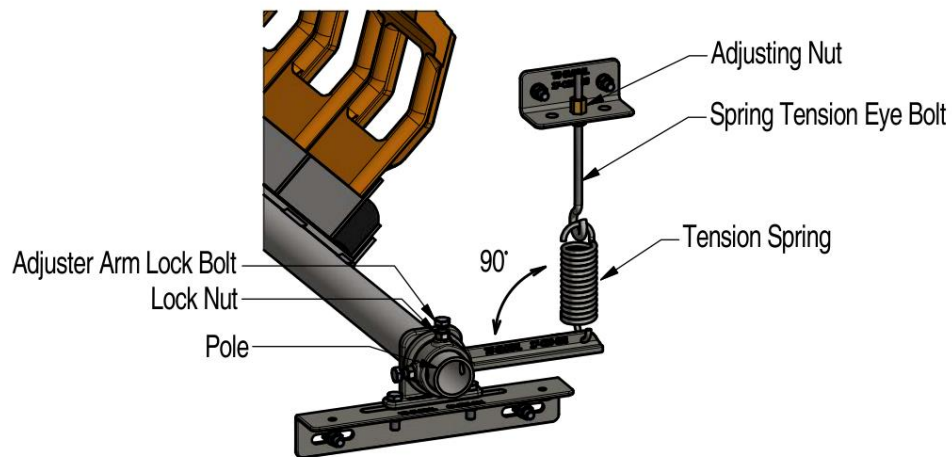

5. Rotate the cleaner upward until the blades touch the belt (refer fig 3b).
6. Centre the blades across the belt and tighten all collar and pivot mount bolts to retain the cleaner in the centre position (refer figure 3a).
7. With both collars tightened, allow the cleaner to rotate and the polyurethane blades to hang in the downwards position.
8. Assemble the spring tensioner. Ensure there is 100-125mm of take-up adjustment on the eye bolt.
9. Install the adjusting arm onto one end of the cleaner. Do not tighten adjuster arm bolts onto pole.
10. Identify the location for the spring tension adjuster bracket onto the structure. This bracket can be located with the adjuster arm at any starting angle provided the spring is at 90 degrees (perpendicular) to the adjuster arm.
11. Clamp and secure the spring tension adjust bracket by welding or bolting into position.
12. For dual side tensioned cleaners repeat steps 8-10 on the opposite side.
13. With the spring and adjuster arm remaining perpendicular, rotate the cleaner until the polyurethane blades are parallel to the belt surface and tighten the adjuster arm bolts.

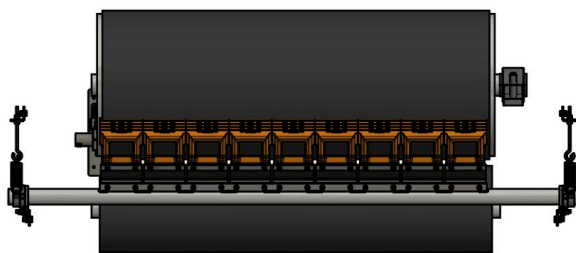

Fig. 3a  
Cleaner centred to the pulley

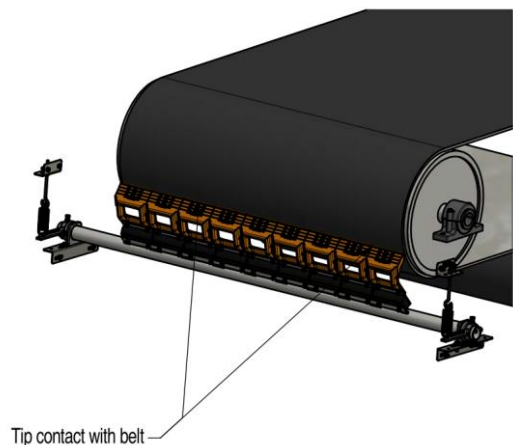
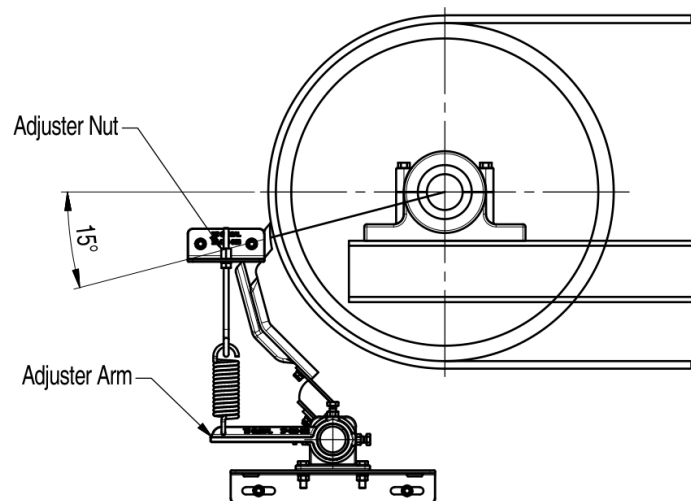

Fig. 3b  
Cleaner aligned with belt

## Pole Adjustment and Blade Tension

1. With the polyurethane blades contacting the belt, apply tension to the blades by lowering the bottom brass nut on the eye bolt and tensioning the top brass nut on the eye bolt.
2. Using a blade tension spring scale for measurement, continue to adjust the tension (as per step 1) evenly on both sides (if applicable) until blades have an applied tension of 8-10kgs.
3. Once correct and even tension has been applied, tighten the bottom brass nut on the eye bolt so that the eye bolt position is secured.



4. Cleaner is now installed.

## Section 4 – Pre Operation Checklist and Testing

### Pre-Operation Checklist

- Recheck that all fasteners are secured
- Check blades are in full contact on the belt
- Check coordinates of cleaner pole
- Be sure that all installation materials and tools have been removed from the belt and the conveyor area.

### Test Run the Conveyor

- Remove isolation in line with site procedures
- Run the conveyor for at least 15 minutes and inspect the product performance
- Check all components for proper positioning and tensioning
- Check cleaner for excessive vibration or material passing blades
- Make adjustments as necessary. In some case this may require isolation of the conveyor.

**NOTE:** Observing the product when it is running and performing properly will help to detect problems. If vibration occurs or material is passing blades refer to section 6 - troubleshooting

## Section 5 – Maintenance

TS Global products are designed to operate with minimum maintenance, however, to maintain superior performance some service is required. When the product is installed, a regular inspection and maintenance program should be established. This program will ensure that the product operates at optimal efficiency and problems can be identified and rectified before reduction in performance occurs.

### Routine Visual Inspection (Recommended every 4 weeks)

A visual inspection of the cleaner and belt can determine:

- If cleaner blades are in full contact with belt
- If the belt looks clean and cleaner has correct tension
- If the blades or cushions are worn out and need to be replaced
- If there is damage to other cleaner components
- If material is built up on the cleaner
- If there is cover damage to the belt
- If there is vibration of the cleaner

If any of the above conditions exist, a determination should be made on when the conveyor can be stopped for maintenance.

### Routine Physical Inspection (Recommended every 3 months)

When the conveyor is not in operation and isolated, undertake a physical inspection of the product to perform the following tasks:

- Clean material build up off cleaner
- Closely inspect the blades and cushions for wear and/or any damage Replace if needed
- Ensure full contact of blades across belt
- Inspect all fasteners for tightness and wear. Tighten or replace as needed
- Replace any worn or damaged components
- Ensure cleaner has correct tension
- When maintenance tasks are completed, test run the conveyor to ensure the cleaner is performing correctly

## Blade and Cushion Service Instructions

1. Prior to commencing blade or cushion replacement, isolate conveyor as per site regulations.
2. Release all tension on the cleaner blades.
3. Loosen adjuster arms and allow the cleaner blades to lay backwards.
4. Remove cleaner from chute.
5. Place cleaner in safe area to allow blade and cushion service or take to workshop for overhaul.
6. Remove all cushions and blades and inspect for damage.
7. Check pole for straightness and wear.
8. Check all components for wear and replace as required.
9. Replace blades and cushions and align blades. When replacing blades and cushions, ensure both flat and spring washers are utilised with the nyloc nuts to prevent any possibility of blades coming loose.
10. Reinstall and adjust cleaner as detailed in Section 3 Cleaner Installation and Pole Position and Tensioning.

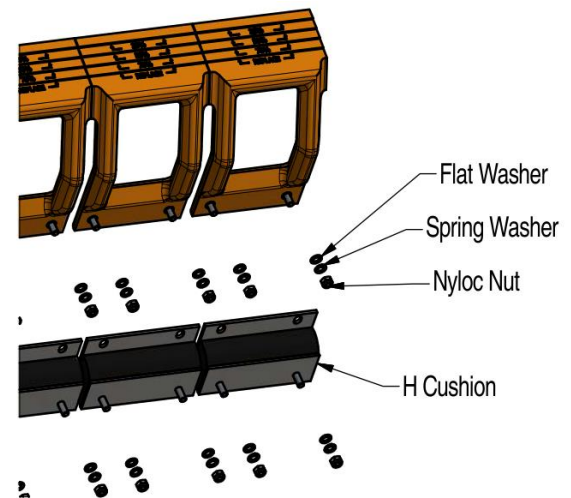

## Pre-Operation Checklist

- Recheck that all fasteners are secured
- Check blades are in full contact on the belt
- Check coordinates of cleaner pole
- Be sure that all installation materials and tools have been removed from the belt and the conveyor area.

## Test Run the Conveyor

- Remove isolation in line with site procedures
- Run the conveyor for at least 15 minutes and inspect the product performance
- Check all components for proper positioning and tensioning
- Check cleaner for excessive vibration or material passing blades
- Make adjustments as necessary. In some case this may require isolation of the conveyor.

**NOTE:** Observing the product when it is running and performing properly will help to detect problems. If vibration occurs or material is passing blades refer to section 6 - troubleshooting

## Section 6 – Troubleshooting

<b>Problem</b>	<b>Possible cause</b>	<b>Possible solution</b>
<b>Vibration</b>	Cleaner pivots or mounting bolts loose	Ensure all locking nuts are tight
	Cleaner not set up correctly	Ensure cleaner set up properly (check blade attack angle with coordinates) Cleaner may need to be adjusted under pulley on Y coordinate
	Belt deformed on pulley	Clean or replace pulley lagging
	Cleaner over tensioned	Ensure cleaner is correctly tensioned
	Cleaner under tensioned	Ensure cleaner is correctly tensioned
<b>Material build up on cleaner</b>	Cleaner not set up correctly	Ensure cleaner set up properly (check blade attack angle with coordinates)
	Excessive sticky material	Frequently clean unit of build-up.
<b>Damaged belt cover</b>	Cleaner over-tensioned	Check cleaner is correctly tensioned
	Cleaner blade damaged	Check blades for wear or damage, replace where necessary
	Attack angle not correct	Ensure cleaner set up properly (check blade attack angle with coordinates)
	Material built up in chute	Frequently clean unit of build up
<b>Cleaner not conforming to belt</b>	Cleaner not set up properly	Ensure cleaner set up properly (check blade attack angle with coordinates)
	Cleaner cannot conform to belt profile	Align cushions and blades detailed in Section 3
	Wear profile in belt cover	Align cushions and blades as detailed in Section 3
<b>Material passing cleaner</b>	Cleaner not set up properly	Ensure cleaner set up properly (check blade attack angle with coordinates)
	Cleaner tension too low	Ensure cleaner is correctly tensioned
	Cleaner blades worn or damaged	Check blades for wear, damage and replace where necessary
	Belt deformed on pulley	Replace pulley lagging
	Build up on lagging	Clean down lagging or replace lagging
	Wear profile in belt cover	Align cushions and blades as detailed in section 3
<b>Missing material in belt centre only</b>	Lagging damaged	Align cushions and blades as detailed in section 3
	Cleaner blades worn/damaged	Check blades for wear or damage and replace where necessary
<b>Missing material on outer edges only</b>	Crowned pulley	Set up cushions as detailed in section 3
	Cleaner blades worn/damaged	Check blades for wear or damage and replace where necessary

## Section 7 – Replacement Parts

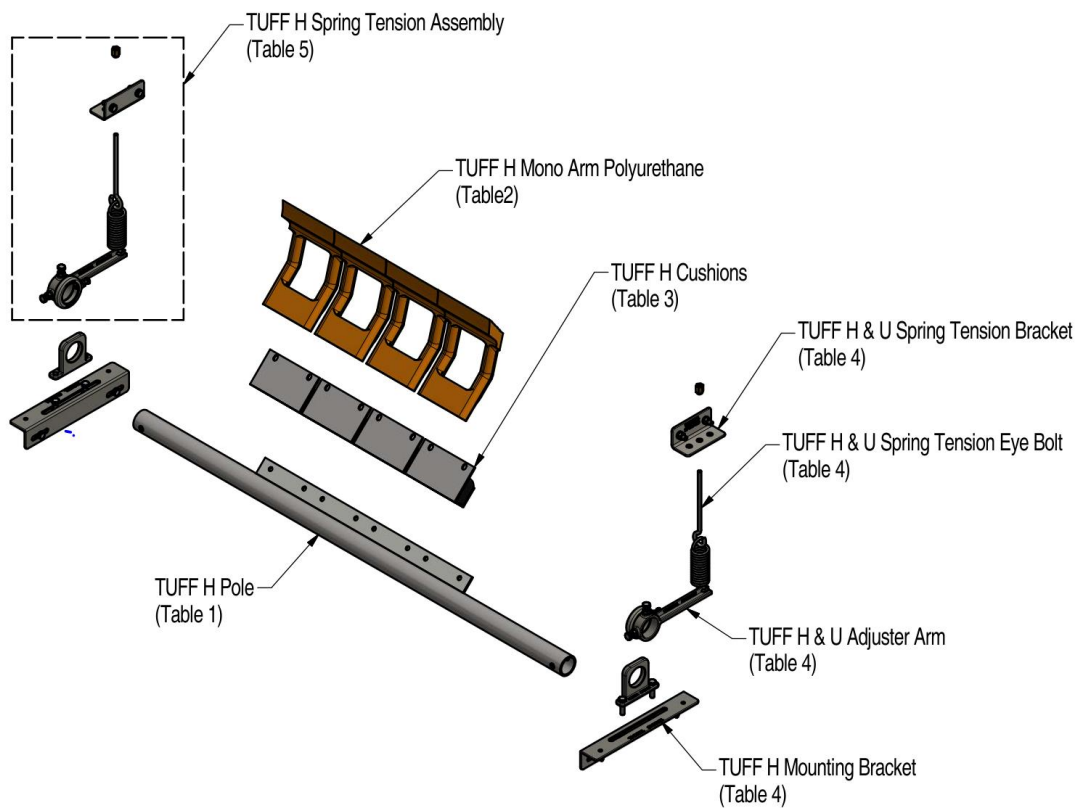

Description	Standard Pole	Reinforced Pole
Tuff H Pole 450	13-C11-001	N/A
Tuff H Pole 600	13-C11-002	N/A
Tuff H Pole 750	13-C11-003	N/A
Tuff H Pole 900	13-C11-004	N/A
Tuff H Pole 1050	13-C11-005	13-C12-001
Tuff H Pole 1200	13-C11-006	13-C12-002
Tuff H Pole 1400-1500	13-C11-007	13-C12-003
Tuff H Pole 1600	13-C11-008	13-C12-004
Tuff H Pole 1800	13-C11-009	13-C12-005

Description	Natural Polyurethane	FRAS Polyurethane
Tuff H Mono Arm Polyurethane SS	13-C10-010	13-C10-014
Tuff H Mono Arm Polyurethane S	13-C10-011	13-C10-015
Tuff H Mono Arm Polyurethane M	13-C10-012	13-C10-016
Tuff H Mono Arm Polyurethane L	13-C10-013	13-C10-017

Description	70 shore A Hardness
Tuff H Cushion	13-C10-001

<b>Table 4 - End Assemblies</b>	
<b>Description</b>	
Tuff H Mount for 48 Dia Pole	13-C10-028
Tuff H Adjuster Arm for 48 Dia Pole	17-C10-001
Tuff H Mount for 60 Dia Pole	13-C10-029
Tuff H Adjuster Arm for 60 Dia Pole	17-C10-002
Tuff H Mount for 73 Dia Pole	13-C10-030
Tuff H Adjuster Arm for 73 Dia Pole	17-C10-003
Tuff H Mounting Bracket	17-C10-001
Tuff H & U Spring Tension Eye Bolt	17-C13-001
Tuff H & U HD Tension Spring	17-C13-002
Tuff H & U Spring Tension Bracket	17-C13-003

<b>Table 5 – Spring Tension Assemblies</b>	
<b>Description</b>	
Tuff H Spring Tension Assembly for 48 Dia Pole	13-A10-001
Tuff H Spring Tension Assembly for 60 Dia Pole	13-A10-002
Tuff H Spring Tension Assembly for 73 Dia Pole	13-A10-003



# TSGlobal<sup>®</sup>

Leaders in Conveyor Products

DISTRIBUTED BY