

# U Tungsten Belt Cleaner



**TSGlobal**<sup>®</sup>

Leaders in Conveyor Products

Installation, Operation and Maintenance Manual

## Contents

Section 1 – Important Information .....	3
General Information .....	3
User Benefits.....	3
Service Option.....	3
Warranty .....	3
Section 2 – Safety Considerations, Precautions and Correct Storage .....	5
Operating Conveyors .....	5
Isolated Conveyors.....	5
Correct Storage .....	5
Section 3 – Installation Instructions.....	6
Checklist .....	6
Suggested Tools Required for Installation .....	7
Install Mounting Assemblies .....	8
Cleaner Installation and Blade Alignment .....	9
Blade Tension.....	11
Section 4 – Pre Operation Checklist and Testing .....	13
Pre-Operation Checklist .....	13
Test Run the Conveyor.....	13
Section 5 – Maintenance .....	14
Routine Visual Inspection (Recommended every 4 weeks).....	14
Routine Physical Inspection (Recommended every 3 months) .....	14
Blade Service Instructions.....	14
Pre-Operation Checklist .....	15
Test Run the Conveyor.....	15
Section 6 – Troubleshooting .....	16
Section 7 – Replacement Parts .....	17

# Section 1 – Important Information

## General Information

TS Global is pleased that you have selected one of our products for your conveyor system.

This manual will assist in the understanding and operation of the product and allow it to perform at its maximum efficiency.

For safe and efficient operation, it is essential that the information and guidelines presented be properly understood and implemented. This manual will provide safety precautions, storage advice, installation instructions, maintenance procedures, recommended spares and troubleshooting tips.

If, however, you have any questions or problems that are not covered in this manual, please contact the nearest authorised distributor or visit our website. [www.tsglobal.net.au](http://www.tsglobal.net.au)

All persons directly responsible for the installation, operation and maintenance of this product should read this manual thoroughly. Whilst we have attempted to make the installation and service tasks as simple as possible, optimum performance from the product will require correct installation, regular inspections, adjustments and maintenance to maintain maximum efficiency.

## User Benefits

Provided the correct installation and regular maintenance tasks are performed, our product will provide the following benefits to your operation:

- Increase conveyor availability and reliability
- Reduced man-hour labour requirements
- Lower maintenance costs
- Increased service life
- Reduction in Safety Hazards around conveyor
- Reduction in Environmental Impact

## Service Option

This product is designed to be easily installed and serviced by your on-site personnel, however, if you would prefer a complete turn-key service, please contact TS Global for a list of your nearest distributors.

## Warranty

The warranty provided by TS Global Pty Limited ("TS Global") is set out in the TS Global Terms and Conditions of Sale at clauses 6.1 to 6.5 inclusive. Those clauses are set out below: -

**6.1** Subject to these conditions of sale, TS GLOBAL warrants that the Goods are free of defects both in material and workmanship and are of merchantable quality. The liability of TS GLOBAL pursuant to this warranty or any other warranty implied by operation of any statute including the Competition and Consumer Act 2010 (Cth) (as amended) shall be limited to the cost of replacing defective Goods, the cost of obtaining equivalent Goods, or the cost of repairing the Goods at TS GLOBAL's discretion provided that in all such cases any costs of dismantling and reassembly shall be borne by the Customer.

**6.2** The warranty set out at clause 6.1 is subject to the following:

- a) the warranty applies for a period of 12 months commencing on the date of invoice of the Goods;
- b) the warranty does not apply to consumable components that are subject to normal wear and tear;
- c) the Customer must provide TS GLOBAL with either an invoice number or purchase order number referencing the defective Goods;

- d) the defects to the Goods must have arisen solely from faulty materials or workmanship; and
- e) the damage to the Goods must not arise from:
  - i. incorrect installation of the Goods contrary to the instructions contained within TS Global's Installation and Operation Manuals;
  - ii. improper adjustment, calibration or operation by the Customer;
  - iii. the use of accessories including consumables, hardware, or software which were not manufactured by or approved in writing by TS GLOBAL
  - iv. any contamination or leakages caused or induced by the Customer
  - v. any modifications of the Goods which was not authorised in writing by TS GLOBAL;
  - vi. any misuse of the Goods by the Customer;
  - vii. any use or operation of the Goods outside of the physical, electrical or environmental specifications of the Goods;
  - viii. inadequate or incorrect site preparation;
  - ix. inadequate or improper maintenance of the Goods; or
  - x. incorrect handling of the Goods.

**6.3** If the Goods are not manufactured by TS GLOBAL the guarantee of the manufacturer of those Goods is accepted by the Customer and is the only guarantee given to the Customer in respect of the Goods. TS GLOBAL agrees to assign to the Customer on request made by the Customer the benefit of any warranty or entitlement to the Goods that the manufacturer has granted to TS GLOBAL under any contract or by implication or operation of law to the extent that the benefit of any warranty or entitlement is assignable.

**6.4** Except as provided in these conditions, all express and implied warranties, guarantees and conditions under statute or general law as to merchantability, description, quality, suitability or fitness of the Goods for any purpose or as to design, assembly, installation, materials or workmanship or otherwise are expressly excluded. TS GLOBAL is not liable for physical or financial injury, loss or damage or for consequential loss or damage of any kind arising out of the supply, layout, assembly, installation or operation of the Goods or arising out of TS GLOBAL's negligence or in any way.

**6.5** Nothing in these conditions shall be read or applied so as to exclude, restrict or modify or have the effect of excluding, restricting or modifying any condition, warranty, guarantee, right or remedy implied by law (including the Competition and Consumer Act 2010) and which by law cannot be excluded, restricted or modified.

This Warranty Statement must be read in conjunction with TS Global's Terms and Conditions of Sale which can be located on our website [www.tsglobal.net.au](http://www.tsglobal.net.au)

## Section 2 – Safety Considerations, Precautions and Correct Storage

Before installing, operating, inspecting or maintaining this product, it is important to follow and understand all relevant site and statutory regulations. Please review the following safety information.



All statutory and site regulations must be followed before undertaking the following activities. Failure to follow site safety procedures exposes workers to uncontrolled hazards which can result in serious injury or in extreme cases, fatality.

Personal Protective Equipment (PPE) must be worn to control the foreseeable hazards associated with conveyor belts. Confined space, tensioning devices and heavy components create a worksite that may expose a worker to harm. Mechanical devices such as cranes or chain blocks can reduce exposure to harm.

Once hazards have been identified, the installer should undertake written Job Hazard Analysis according to site requirements. The installer must identify all hazards and apply appropriate controls before proceeding with the installation or servicing of this equipment.

There are installation, maintenance and operational activities involving both isolated and operating conveyors. Each has a safety protocol and it is your responsibility to be familiar with the site requirements.

### Operating Conveyors

There are two routine tasks that should be performed while the conveyor is running:

- Inspecting the performance and operation of the product
- Dynamic troubleshooting

### Isolated Conveyors

The following activities are performed on isolated conveyors:

- Installation
- Parts replacement
- Repair
- Cleaning
- Adjustment

### Correct Storage

Provided goods remain stored within boxes or on pallets wrapped with plastic, TS Global products can be stored outside in all weather conditions. If packaging is damaged or removed, TS Global recommends that the products be stored under cover and out of direct sunlight to minimise deterioration of any componentry.

## Section 3 – Installation Instructions

### Checklist

- Check that the product size is correct for the conveyor to be installed on
- Check the product and make sure all the parts have been supplied
- Review the “Tools Needed” listed on page 7 of the Installation instructions
- Check the installation location: will the cleaner have clearance inside chute

### Before you begin:

- Familiarise yourself with the main components of this product (Fig. 1a)
- Determine the install location and check for clearances (Fig 1b)
- Follow all safety precautions and site hot work procedures (If required)
- Protect all fastener threads and the belt from weld spatter

**Note:** TS Global belt cleaners have been designed to be flexible in installation. In the event that conveyor head chute or structure needs to be modified, seek engineering approval from your site contact, prior to undertaking modification.

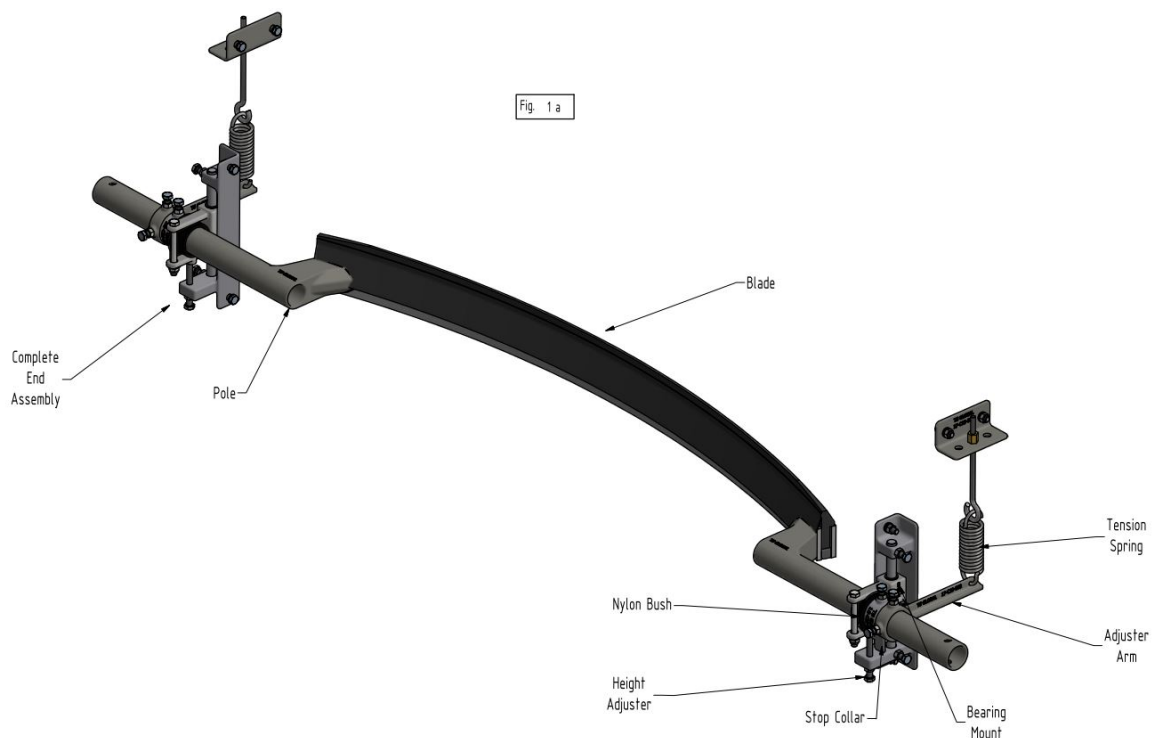
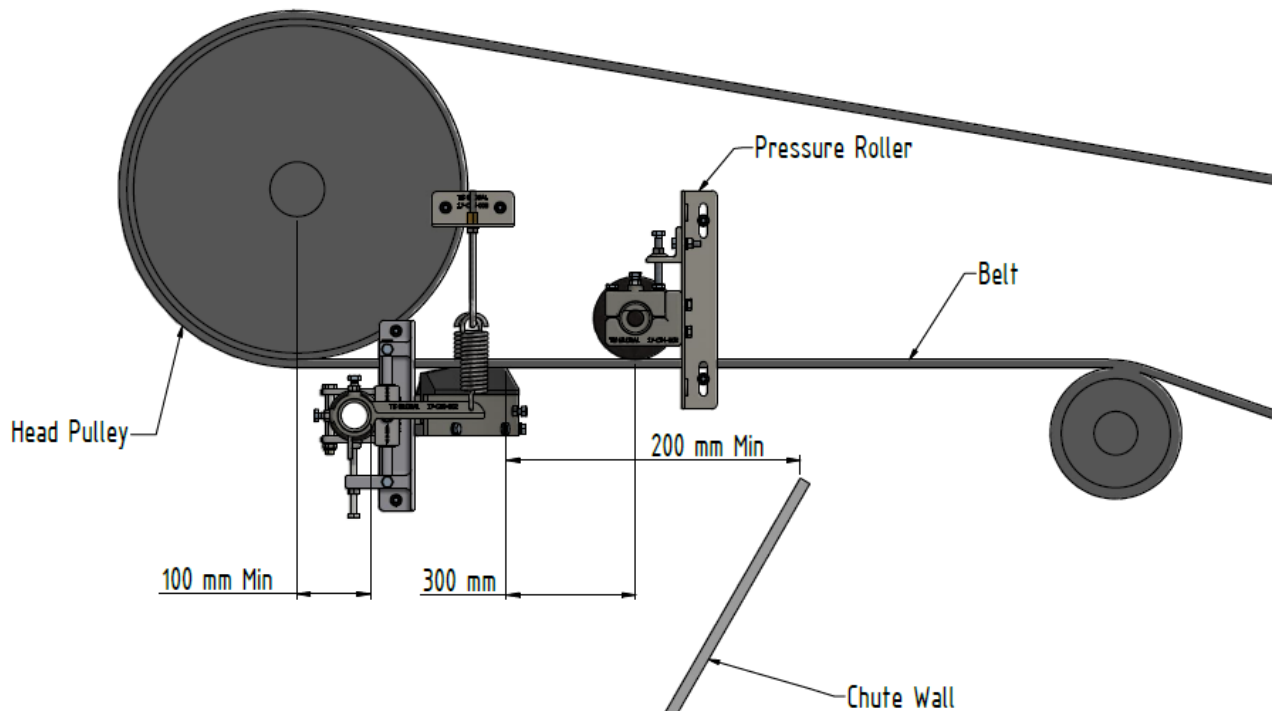

Fig. 1b



**First establish a satisfactory position to mount the U type cleaner.** Positioning the cleaner in the head-chute allows any material removed to remain in the flow of product and reduces the need for any external clean up.

- Ensure the cleaner is positioned 100mm or greater behind the tangent point where the belt leaves the head pulley to prevent blade or belt damage from pinching between the pulley and blade.
- Ensure a minimum of 200mm between the back of the cleaner and the back of the chute to prevent bridging of material build-up inhibiting cleaner operation.
- Install a pressure roller if required to stabilise or flatten the belt. The pressure roller should be approximately 300mm or more from the cleaner blade to allow the belt to conform to the blade profile during operation.

#### Suggested Tools Required for Installation

- Tape measure
- Marking Pen
- Level
- 2 x 150mm G Clamps
- 2 x 17mm Spanners
- 2 x 19mm Spanners
- Cutting Torch and or Welder
- Grinder
- Drill
- Various drill bits up to 13mm

## Install Mounting Assemblies

For a chute installation the belt location must first be established.

1. Draw a belt location line (Fig. 1c) on the chute replicating this location. If head pulley and snub pulley are close, it may be necessary to assume an approximate belt location line between the two.
2. In the determined cleaner location (refer to Fig 1b) draw a line perpendicular to the belt line.
3. Draw a parallel Pole Height Line 85mm below the belt location line (Fig. 1c).

Fig. 1c

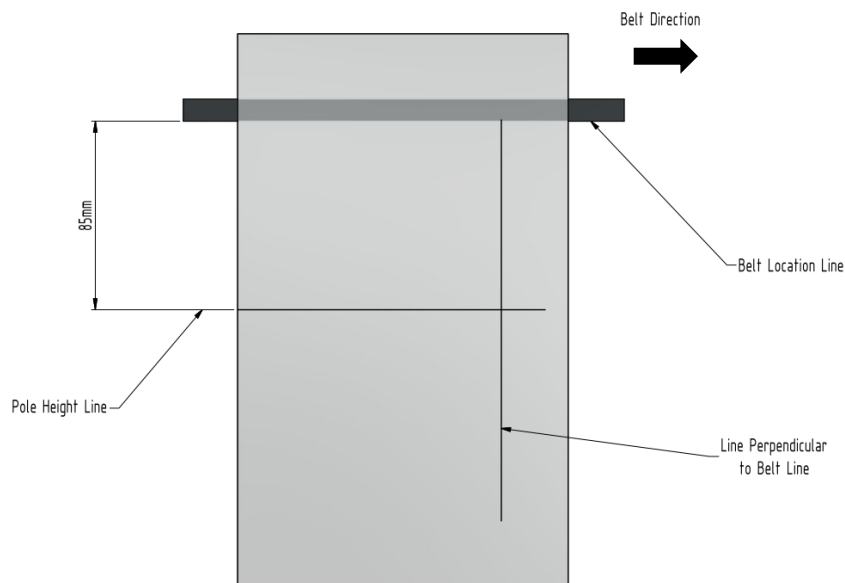

4. Locate a mounting bracket along these lines allowing the centreline of the pole to align with the pole height line (Fig. 1d).

Fig. 1d

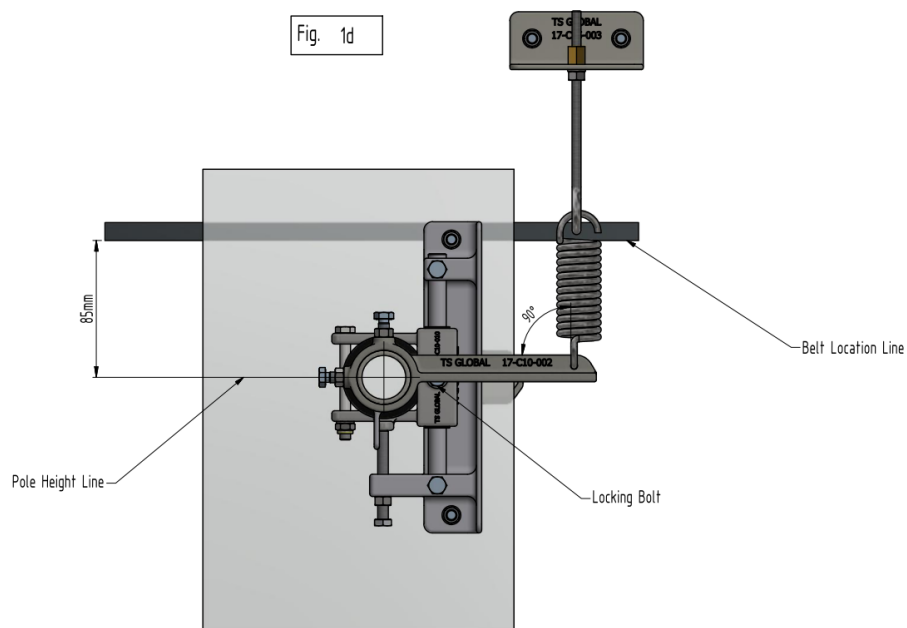

5. To move the bearing mount, if necessary; loosen the locking bolt and move the bearing mount to a position where the centre of the hole is 85mm below the bottom of the belt.
6. Once location is determined and clearances checked cut outs are required (Fig 1e)

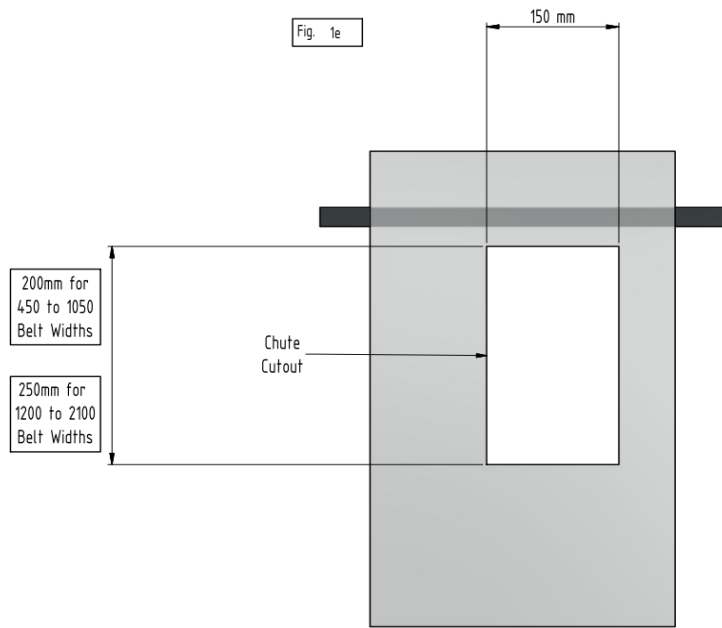

7. Bolt or weld mounting bracket and spring tension bracket in place (Fig 1f)

**Note:** Spring tension bracket must be perpendicular (90 degrees) to the adjuster arm.

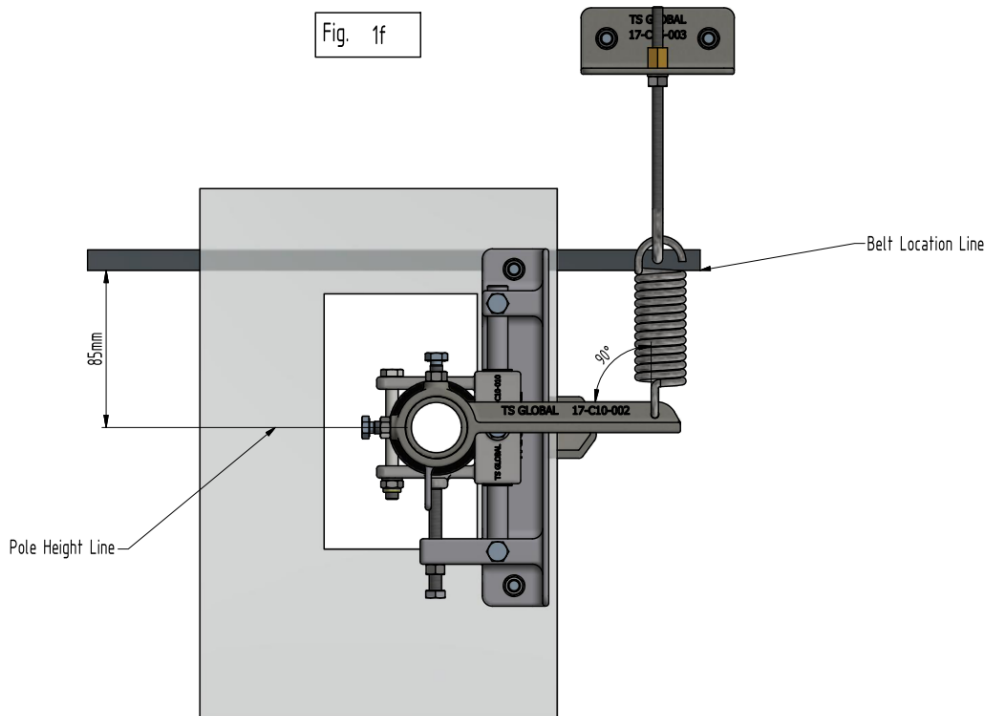

8. Repeat steps 1-7 on the opposite side.

### Cleaner Installation and Blade Alignment

1. Remove nylon bush, adjuster arm and spring from install side and slide the pole through the chute into a central position.



2. Slide on nylon bush and place pole into bearing mount.
3. Fit stop collar but do not tighten
4. Rotate cleaner to contact belt. Tighten a stop collar against the tab to prevent cleaner rotating back

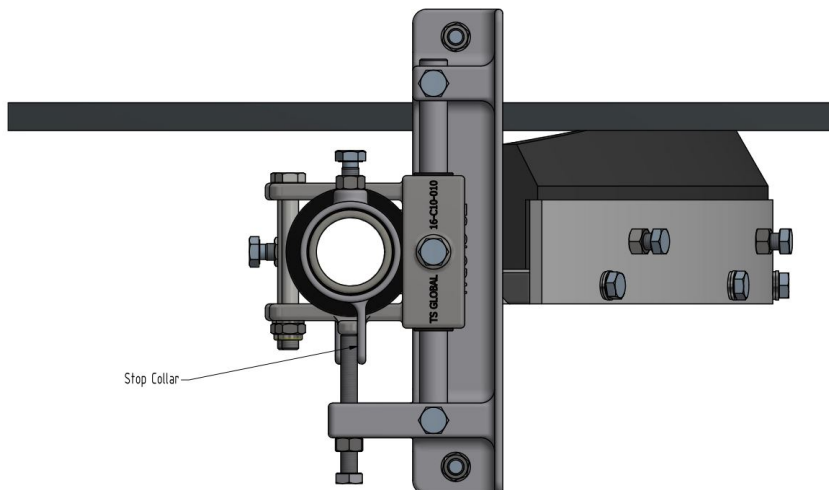

5. Fit adjuster arm and spring to install side.
6. Cleaner blade should be in full contact with the belt at both ends and in centre.

**NOTE:** If the belt profile is not flat. Pressure or stabilizing rollers should be installed to flatten belt



7. If the blade first contacts in the centre of the belt pole will need to be raised using adjuster bolt

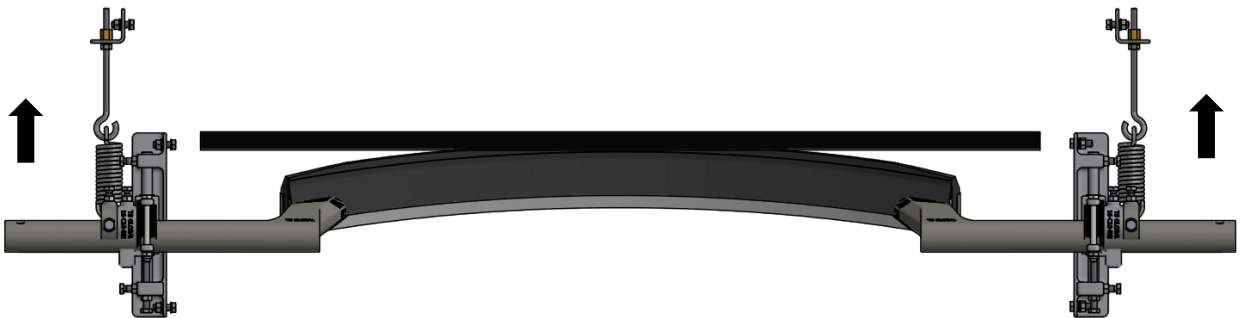

8. If the blade first contacts at either end and not the centre of the belt pole will need to be lowered using the adjuster bolt.

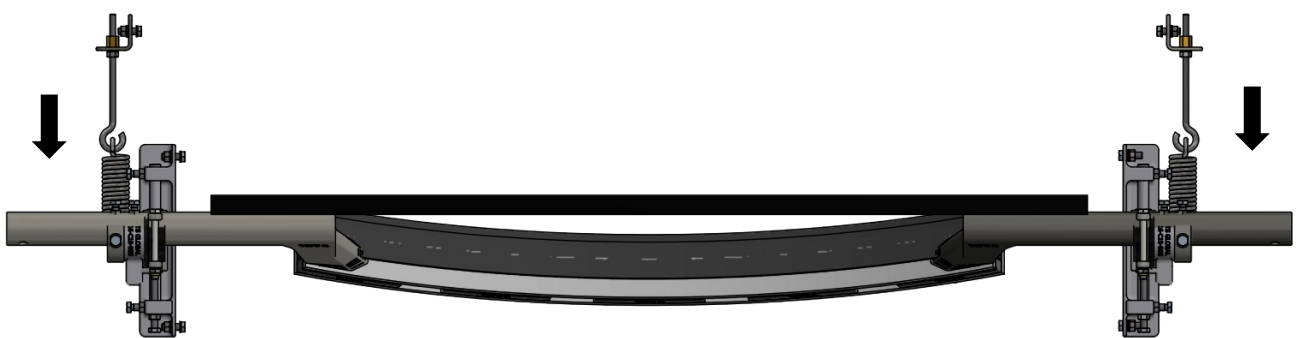

9. With blade now aligned at both ends and in centre. Tighten adjuster arm

Blade Tension

With the blade contacting the belt, apply tension to the blade by lowering the locking nut on the eye bolt and tensioning the top adjuster nut.

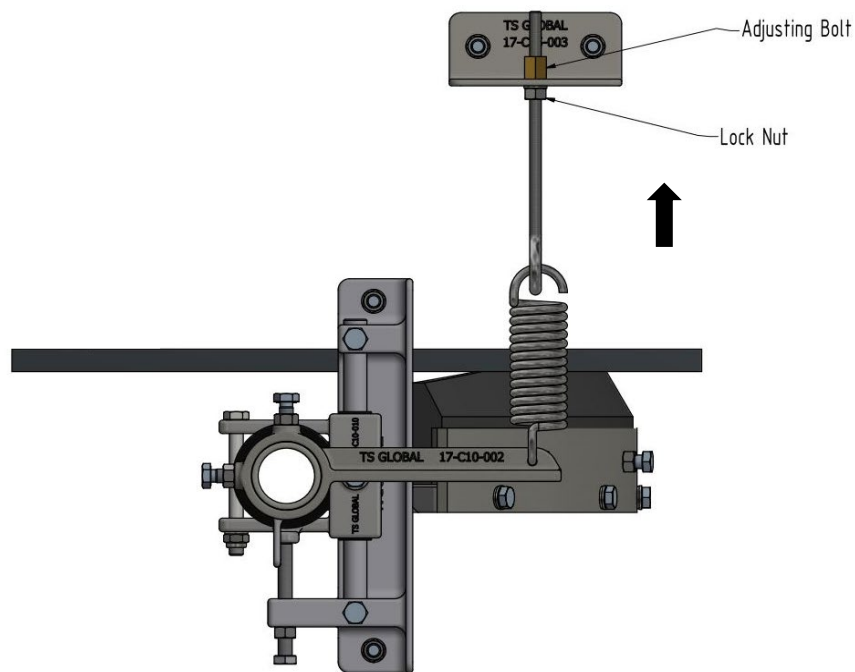

As a guide the spring should have 1 to 2 mm gap between coils. (Thickness of a credit card.)

Once blade is at correct tension tighten the bottom locking nut.

## Section 4 – Pre Operation Checklist and Testing

### Pre-Operation Checklist

- Recheck that all fasteners are tightened properly
- Check blade is in full contact area on the belt
- Check positioning of cleaner pole
- Be sure that all installation materials and tools have been removed from the belt and the conveyor area.
- Ensure any removed guarding has been returned into position

### Test Run the Conveyor

- Remove isolation
- Run the conveyor for at least 15 minutes and inspect the product performance
- Check all components for proper positioning and tensioning
- Check cleaner pole for excessive vibration or material passing blade
- Make adjustments as necessary. In some case this may require isolation of the conveyor.

**NOTE:** Observing the product when it is running and performing properly will help to detect problems. If vibration occurs or material passing blade refer to section 6.

## Section 5 – Maintenance

TS Global products are designed to operate with a minimum maintenance, however, to maintain superior performance some service is required. When the product is installed, a regular maintenance program should be established. This program will ensure that the product operates at optimal efficiency and problems can be identified and rectified before reduction in performance occurs.

### Routine Visual Inspection (Recommended every 4 weeks)

A visual inspection of the cleaner and belt can determine:

- If cleaner blade in full contact with belt
- If the belt looks clean and cleaner has correct tension
- If the blade is worn out and needs to be replaced
- If there is damage to other cleaner components
- If excess material is built up on the cleaner
- If there is cover damage to the belt
- If there is vibration of the cleaner

If any of the above conditions exist, a determination should be made on when the conveyor can be stopped for maintenance.

### Routine Physical Inspection (Recommended every 3 months)

When the conveyor is not in operation and isolated, undertake a physical inspection of the product to perform the following tasks:

- Clean material build up off cleaner
- Closely inspect the blade for wear and any damage and replace if needed
- Ensure full contact of blade across belt
- Inspect all fasteners for tightness and wear. Tighten or replace as needed
- Replace any worn or damaged components
- Ensure cleaner has correct tension
- When maintenance tasks are completed, test run the conveyor to ensure the cleaner is performing correctly

### Blade Service Instructions

1. Prior to commencing blade replacement, isolate conveyor as per site regulations.
2. Release all tension on the cleaner blade by loosening adjuster nut
3. Remove bearing mount and adjuster arm
4. Remove pole assembly
5. Place pole in safe area to allow blade service or take to workshop for overhaul
6. Remove the worn or damaged blade by loosening the blade retaining bolts
7. Check pole for straightness and wear
8. Check all components for wear and replace as required

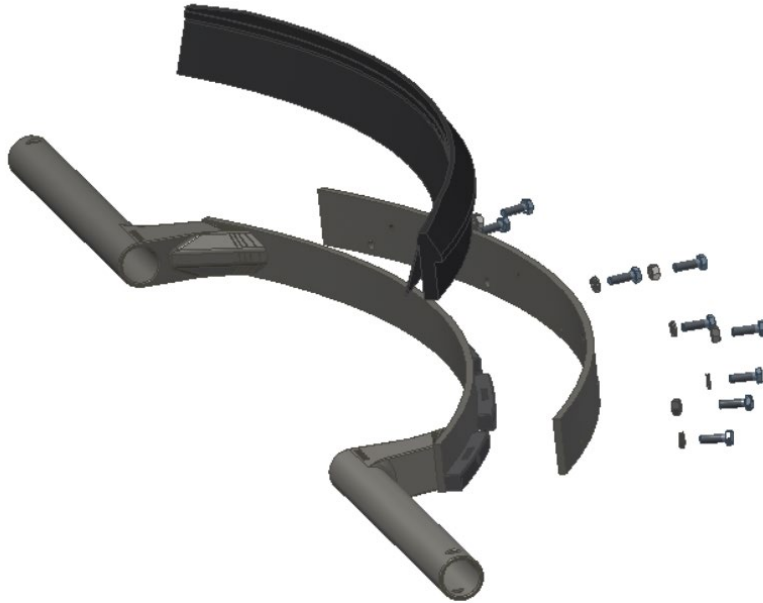

9. Replace blade and retaining bolts
10. Install and adjust cleaner as detailed in section 3

**NOTE:** Observing the product when it is running and performing properly will help to detect problems. If vibration occurs or material passing blade refer to section 6.

### Pre-Operation Checklist

- Recheck that all fasteners are tightened properly
- Check blade in full contact area on the belt
- Check positioning of cleaner pole
- Be sure that all installation materials and tools have been removed from the belt and the conveyor area.
- Ensure any removed guarding has been returned into position

### Test Run the Conveyor

- Remove isolation
- Run the conveyor for at least 15 minutes and inspect the product performance
- Check all components for proper positioning and tensioning
- Check cleaner pole for excessive vibration or material passing blade
- Make adjustments as necessary. In some case this may require isolation of the conveyor.

## Section 6 – Troubleshooting

<b>Problem</b>	<b>Possible cause</b>	<b>Possible solution</b>
<b>Vibration</b>	Cleaner over tensioned	The tension arm is to be at right angles to the spring. The spring should have 1 to 2 mm gap between coils. (Thickness of a credit card.)
	Cleaner under tensioned	The tension arm is to be at right angles to the spring. The spring should have 1 to 2 mm gap between coils. (Thickness of a credit card.)
	Belt flap	Install pressure roller or If pressure roller is installed check it is in good condition and keeping the belt flat and stable. Roller should be 150 to 300mm behind the back of the blade.
<b>Material build up on cleaner</b>	Cleaner not set up correctly	Ensure cleaner is set up properly
	Build up in chute	Ensure cleaner is not located too close to back of chute, allowing build up
	Cleaner being overburdened	Install additional TS Global secondary cleaners
	Excessive sticky material	Frequently clean unit of build-up. Introduce Spray Bar and Water Control Manifold
<b>Damaged belt cover</b>	Cleaner over-tensioned	Check cleaner is correctly tensioned
	Cleaner blade damaged	Check blade for wear, damage and chips, replace where necessary
	Material built up in chute	Frequently clean unit of build up
<b>Cleaner not conforming to belt</b>	Cleaner not set up correctly	Ensure cleaner set up properly (Section 3)
	Wear profile in belt cover	Ensure blade width is suitable for belt profile
	Belt flap	Install stabilising rollers
<b>Material passing cleaner</b>	Cleaner not set up correctly	Ensure cleaner set up properly ( Section 3)
	Cleaner tension too low	Ensure cleaner is correctly tensioned
	Cleaner blade worn or damaged	Check blade for wear, damage and chips, replace where necessary
	Cleaner being overburdened	Install additional secondary cleaner
	Cleaner cannot conform	Install pressure or stabilising rollers
	Wear profile in belt cover	Ensure blade width is suitable for belt profile
<b>Missing material in belt centre only</b>	Wear profile in belt cover	Ensure blade width is suitable for belt profile. Check blade is contacting full width of belt. (page 11)
	Cleaner blade worn/damaged	Check blade for wear, damage and chips, replace where necessary
<b>Missing material on outer edges only</b>	Wear profile in belt cover	Ensure blade width is suitable for belt profile. Check blade is contacting full width of belt. (page 11)
	Cleaner blade worn/damaged	Check blade for wear, damage and chips, replace where necessary

## Section 7 – Replacement Parts

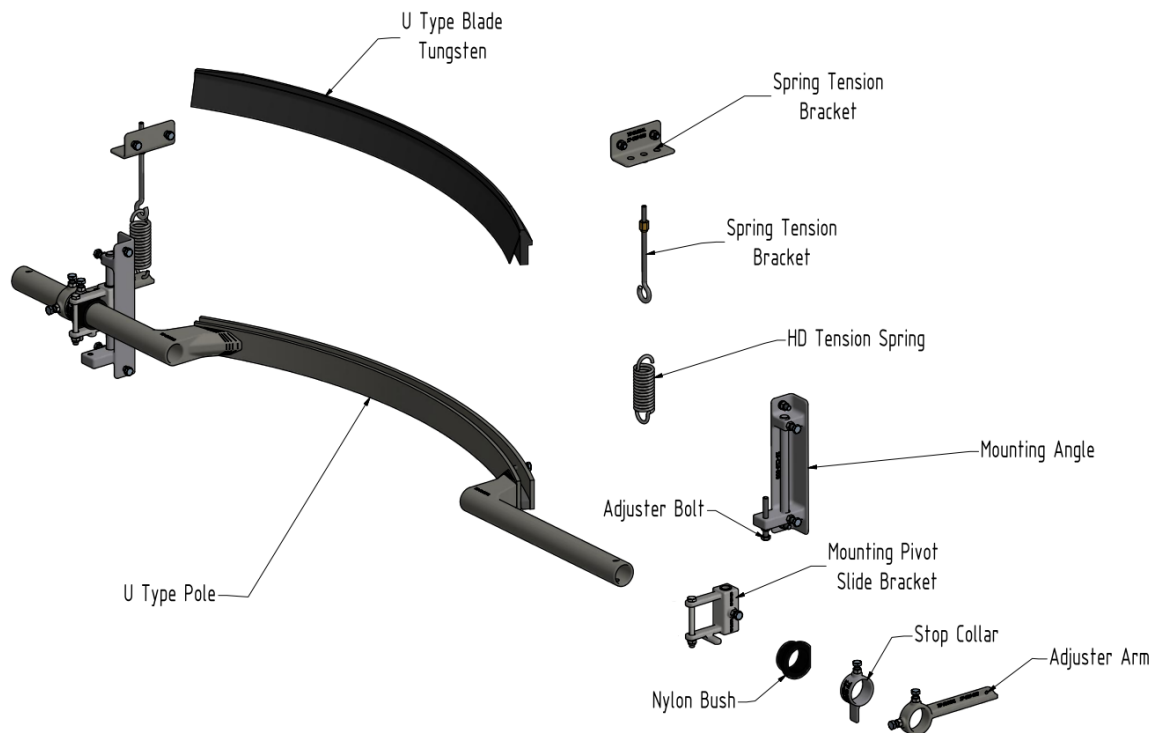

U Type Pole	
Description	Part Number
Tuff U pole 450	16-C11-001
Tuff U pole 600	16-C11-002
Tuff U pole 750	16-C11-003
Tuff U pole 900	16-C11-004
Tuff U pole 1050	16-C11-005
Tuff U pole 1200	16-C11-006
Tuff U pole 1400	16-C11-007
Tuff U pole 1500	16-C11-008
Tuff U pole 1600	16-C11-009
Tuff U pole 1800	16-C11-010
Tuff U pole 2000	16-C11-011

U Type Blade			
Description	Tungsten	Natural Polyurethane	Polyurethane FRAS
Tuff U blade 450	16-C13-001	16-C14-001	16-C15-001
Tuff U blade 600	16-C13-002	16-C14-002	16-C15-002
Tuff U blade 750	16-C13-003	16-C14-003	16-C15-003
Tuff U blade 900	16-C13-004	16-C14-004	16-C15-004
Tuff U blade 1050	16-C13-005	16-C14-005	16-C15-005
Tuff U blade 1200	16-C13-006	16-C14-006	16-C15-006
Tuff U blade 1400	16-C13-007	16-C14-007	16-C15-007
Tuff U blade 1500	16-C13-008	16-C14-008	16-C15-008
Tuff U blade 1600	16-C13-009	16-C14-009	16-C15-009
Tuff U blade 1800	16-C13-010	16-C14-010	16-C15-010
Tuff U blade 2000	16-C13-011	16-C14-011	16-C15-011

<b>U Type End Assembly Complete</b>	
<b>Description</b>	<b>Part Number</b>
TUFF U Complete End Assembly Set for 48 Dia Poles	16-A10-001
TUFF U Complete End Assembly Set for 60 Dia Poles	16-A10-002
TUFF U Complete End Assembly Set for 73 Dia Poles	16-A10-003

<b>U Type Components</b>	
<b>Description</b>	<b>Part Number</b>
Tuff U nylon bush for 48 dia poles	16-C10-001
Tuff U nylon bush for 60 dia poles	16-C10-002
Tuff U nylon bush for 73 dia poles	16-C10-003
Tuff U stop collar for 48 dia poles	16-C10-004
Tuff U stop collar for 60 dia poles	16-C10-005
Tuff U stop collar for 73 dia poles	16-C10-006
Tuff U right hand mounting angle	16-C10-007
Tuff U left hand mounting angle	16-C10-008
TUFF U right hand mounting pivot slide bracket 48 and 60 dia poles	16-C10-009
TUFF U left hand mounting pivot slide bracket 48 and 60 dia poles	16-C10-010
TUFF U right hand mounting pivot slide bracket 73 dia poles	16-C10-011
TUFF U left hand mounting pivot slide bracket 73 dia poles	16-C10-012



# **TS**Global<sup>®</sup>

Leaders in Conveyor Products

DISTRIBUTED BY